

5-2017

## Overused and Neglected: Conceptual Designs for Spaces on Campus

Cayla A. Riehl  
University of Rhode Island, [cayla\\_riehl@my.uri.edu](mailto:cayla_riehl@my.uri.edu)

Follow this and additional works at: <https://digitalcommons.uri.edu/srhonorsprog>



Part of the [Interior Architecture Commons](#)

---

### Recommended Citation

Riehl, Cayla A., "Overused and Neglected: Conceptual Designs for Spaces on Campus" (2017). *Senior Honors Projects*. Paper 532.

<https://digitalcommons.uri.edu/srhonorsprog/532>

This Article is brought to you by the University of Rhode Island. It has been accepted for inclusion in Senior Honors Projects by an authorized administrator of DigitalCommons@URI. For more information, please contact [digitalcommons-group@uri.edu](mailto:digitalcommons-group@uri.edu). For permission to reuse copyrighted content, contact the author directly.

# **OVERUSED AND NEGLECTED**

Conceptual Designs for Spaces on Campus

CAYLA RIEHL

# PROJECT STATEMENT

*Create conceptual designs for existing student spaces on campus that allows for optimal functionality and aesthetic appeal using computer aided design software.*

# **THEAIRPORTLOUNGE**

in the Memorial Union







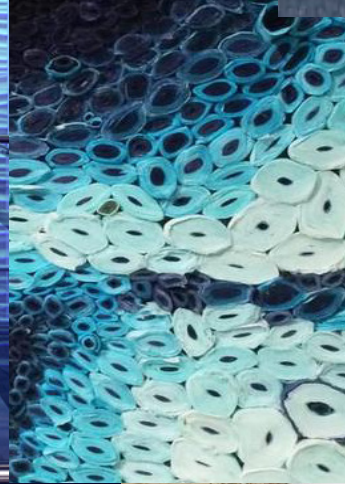
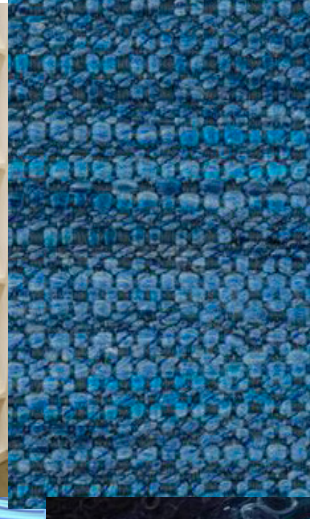



# AUTOCAD DRAFTING: AIRPORT LOUNGE

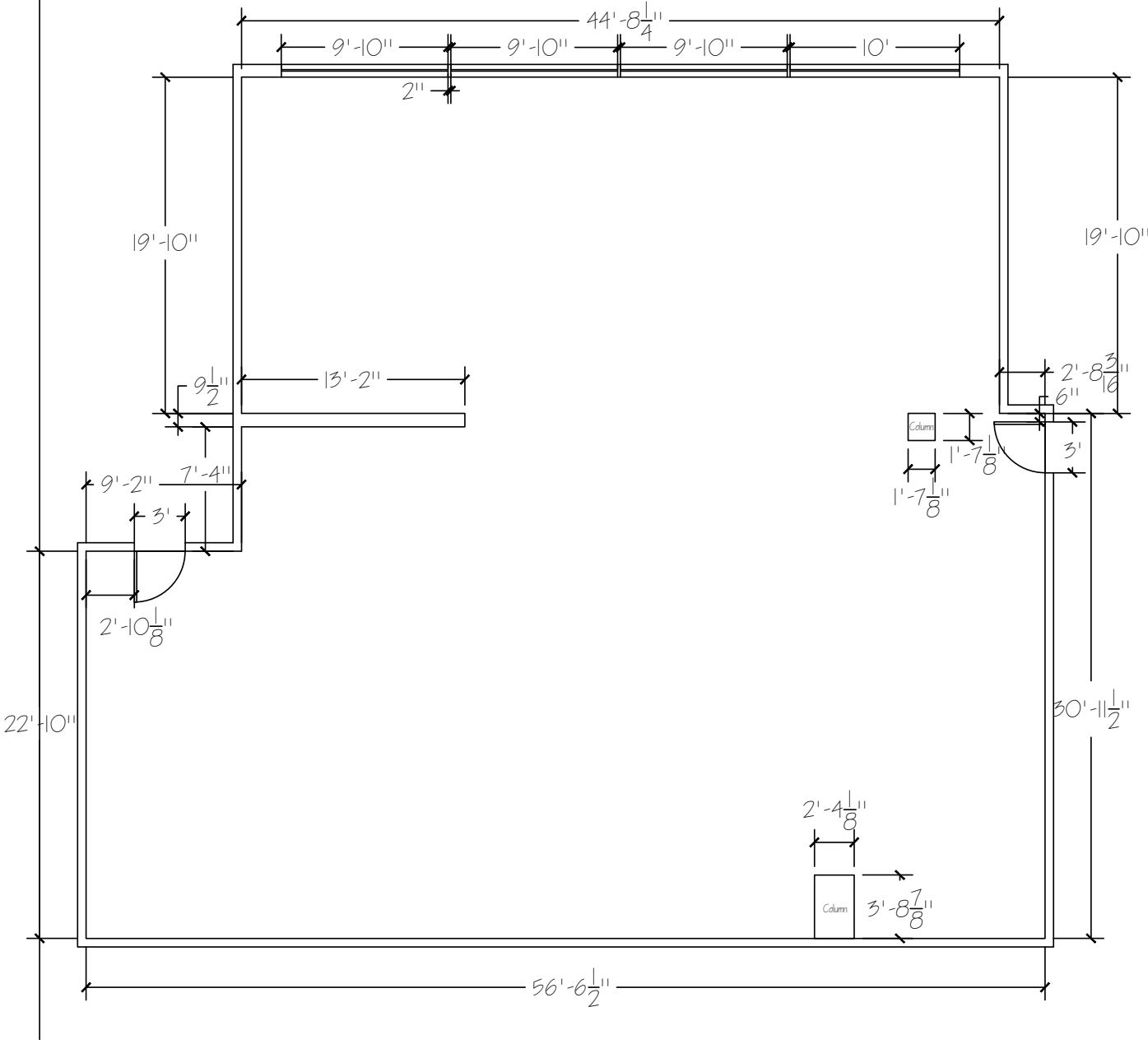



# REVIT RENDERINGS: AIRPORT LOUNGE



# REVIT RENDERINGS: AIRPORT LOUNGE





# REVIT RENDERINGS: AIRPORT LOUNGE



# REVIT RENDERINGS: AIRPORT LOUNGE





# REVIT RENDERINGS: AIRPORT LOUNGE



# **FINEARTSLOUNGE**

in the Fine Arts Building



# CAFÉ ART STUDY AREA

For use by Art & Art History Students  
Furnished by the Department of Art & Art History

- Please do not remove furniture from area
- Please do not mark or damage furniture
- Please keep area clean

*DO NOT TOUCH  
ANY Artwork  
that isn't your own.*

**ATTENTION !!!**  
All Students and Visitors

We continue to have several disturbing incidents of student work and other material being removed from display walls or FAC studios causing problems with grades and personal loss.

**DO NOT REMOVE or disturb ANY  
ART WORKS or other materials at  
any time THAT DO NOT BELONG TO  
YOU**

*•If you do so, you may  
be subject to fines, arrest  
or other penalties•*

The Faculty, Department of Art & Art History







AN  OPENER

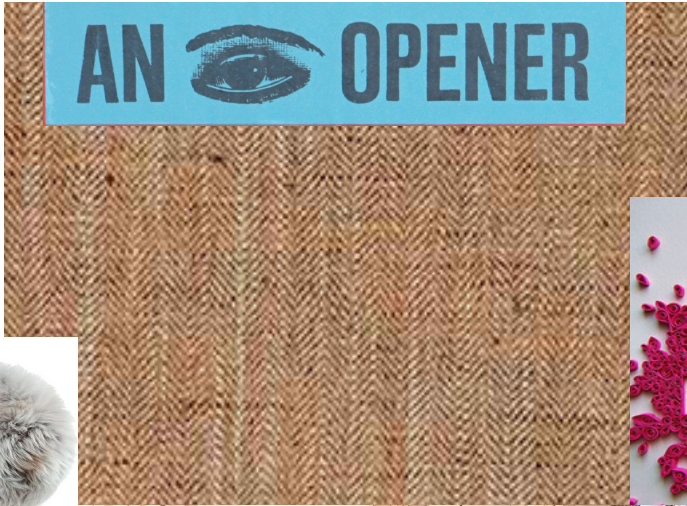
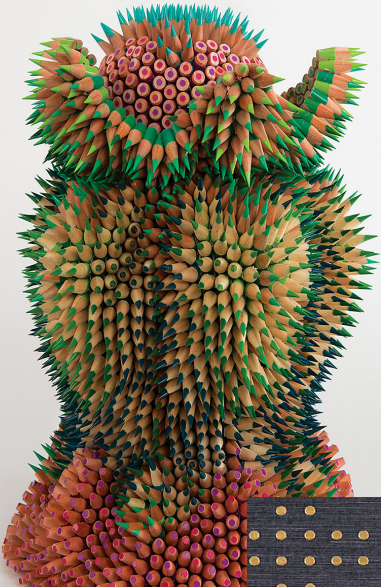



# AUTOCAD DRAFTING: FINE ARTS LOUNGE

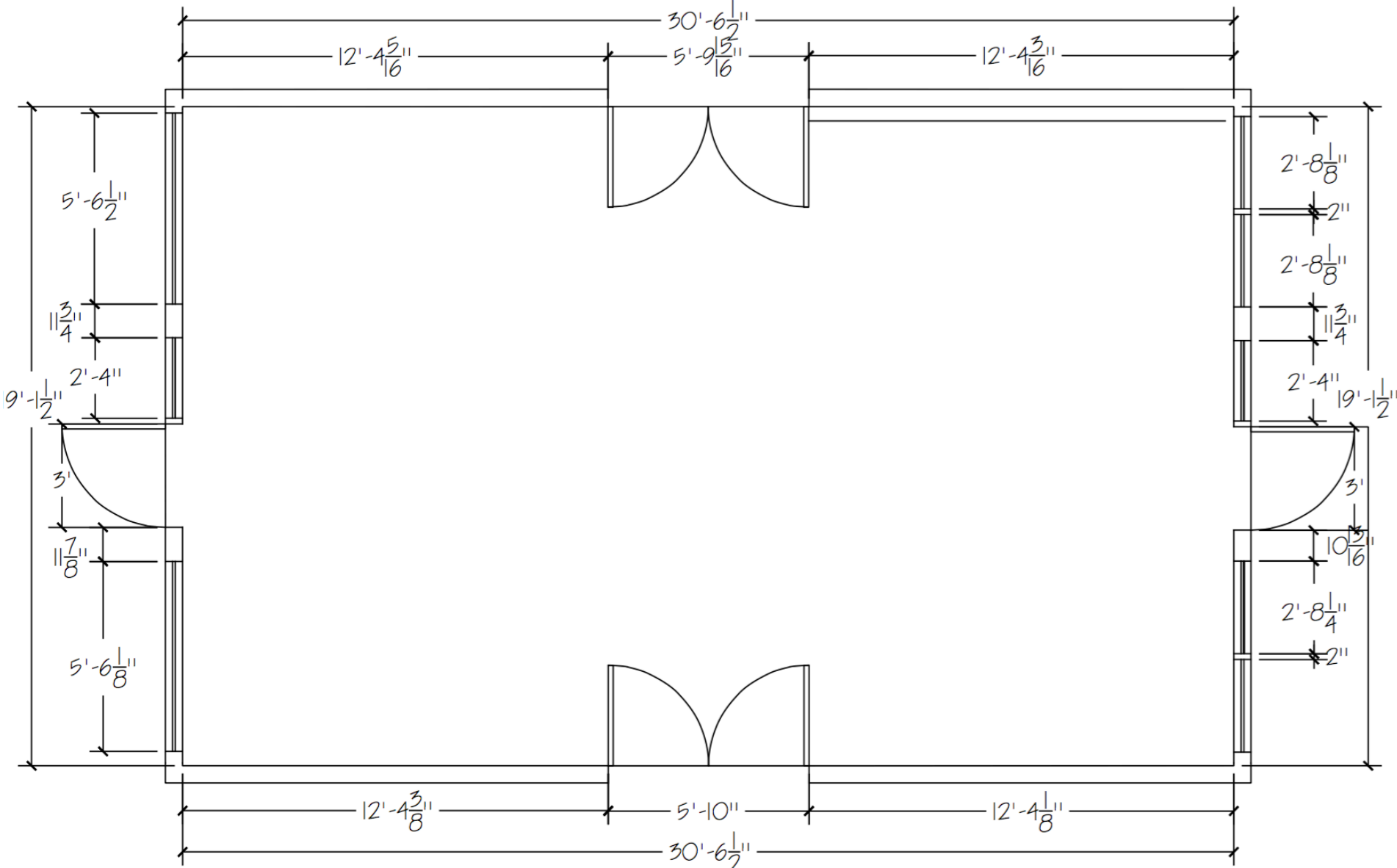

# AUTOCAD DRAFTING: FINE ARTS LOUNGE

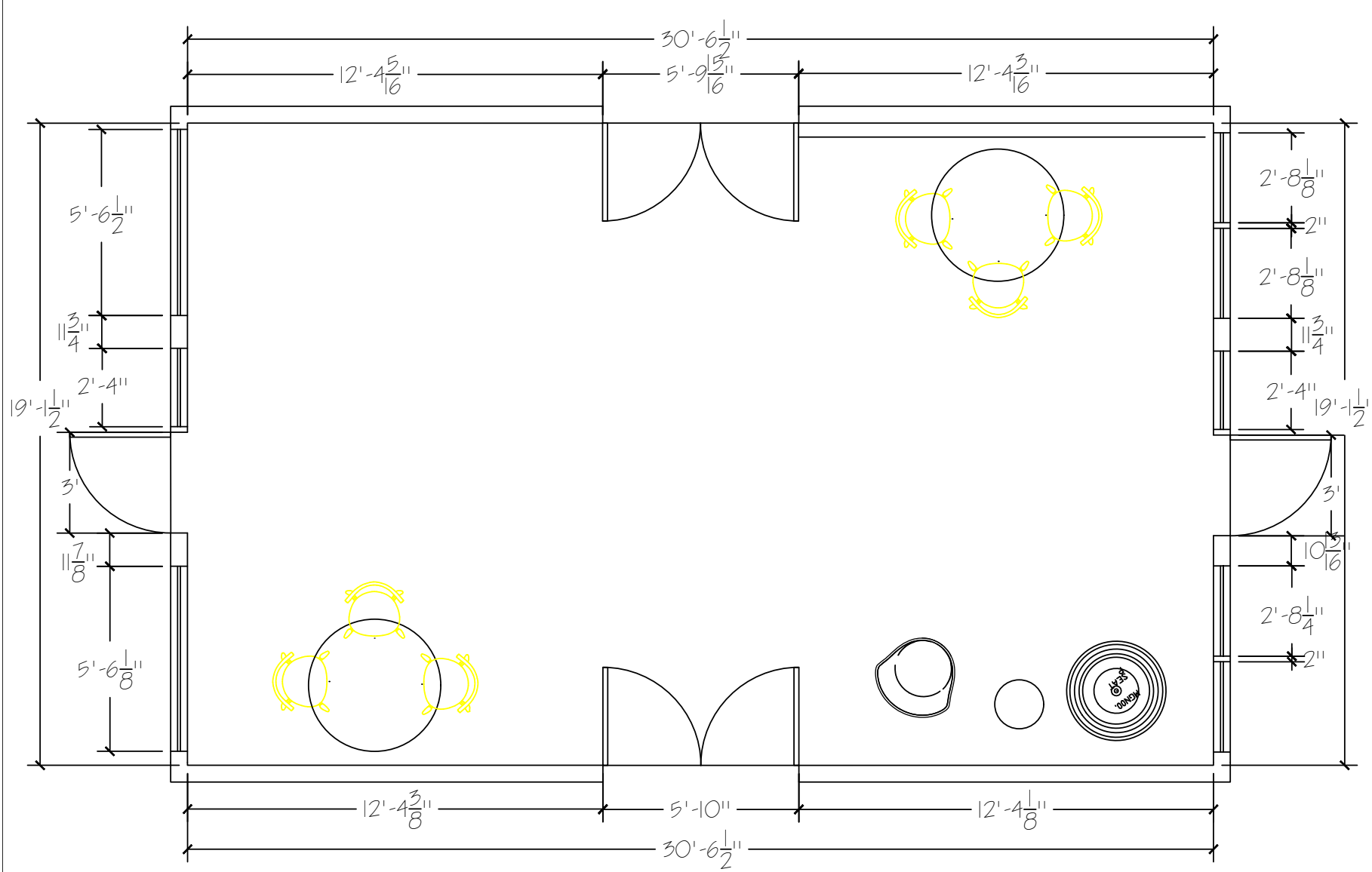

# REVIT RENDERINGS: FINE ARTS LOUNGE





# REVIT RENDERINGS: FINE ARTS LOUNGE



# REVIT RENDERINGS: FINE ARTS LOUNGE



# **HONORSPROGRAMLOUNGE**

in Lippitt Hall





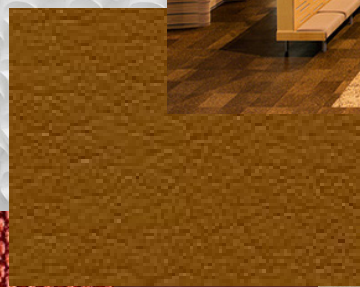
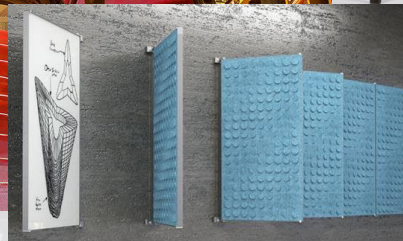

**OLD VS. NEW**



# AUTOCAD DRAFTING: HONORS LOUNGE

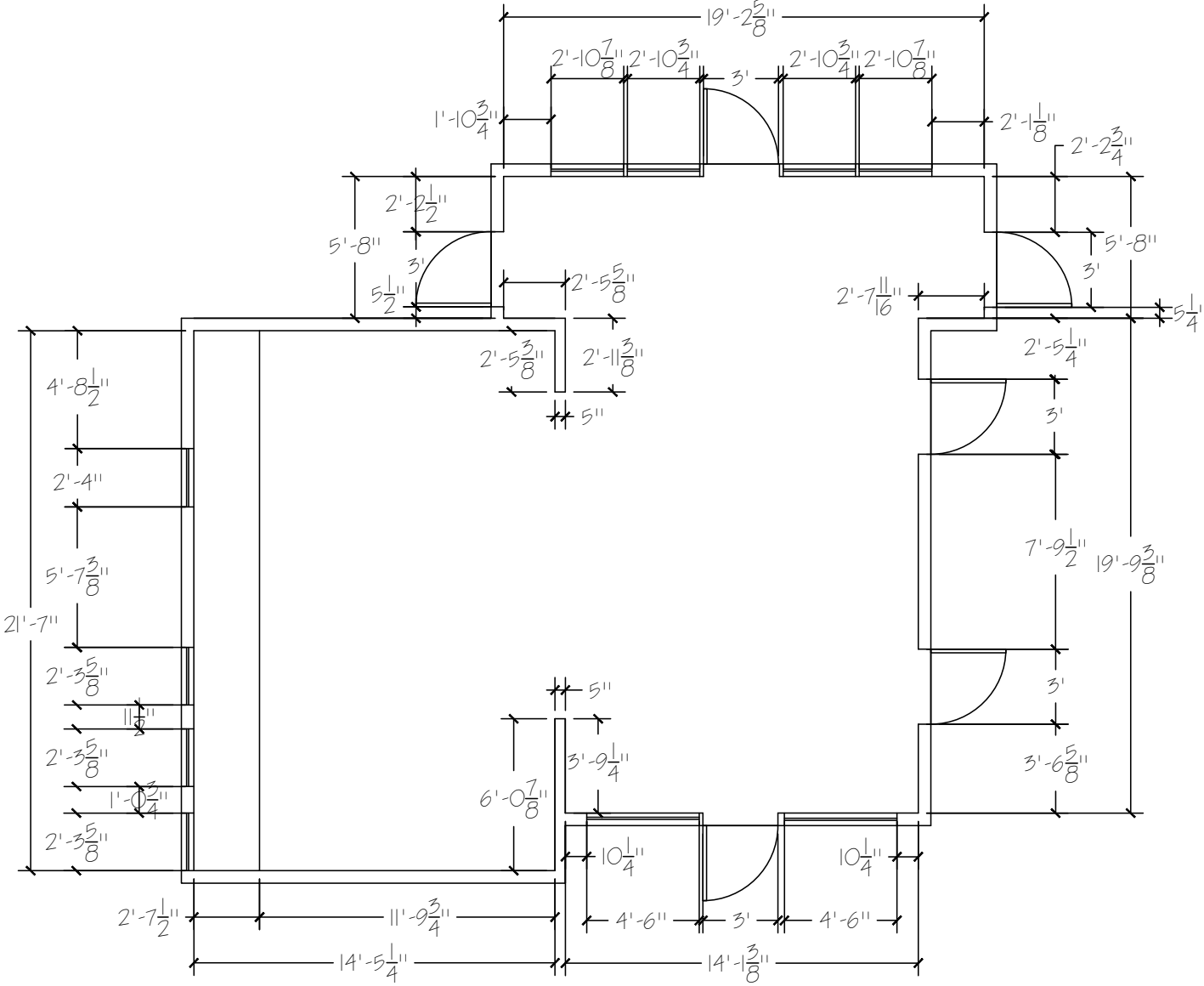

# AUTOCAD DRAFTING: HONORS LOUNGE

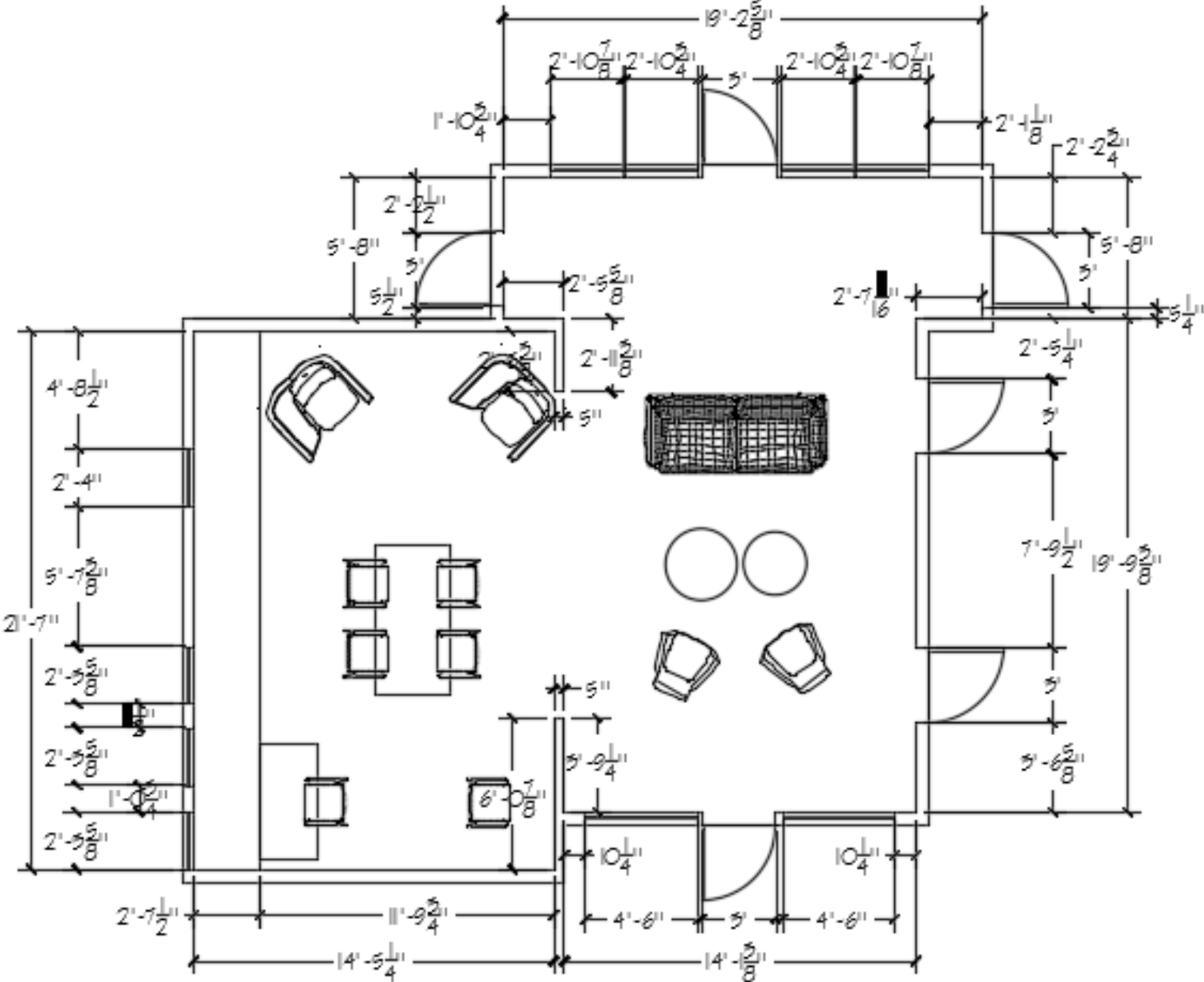

# REVIT RENDERINGS: HONORS LOUNGE





# REVIT RENDERINGS: HONORS LOUNGE





# REVIT RENDERINGS: HONORS LOUNGE



# REVIT RENDERINGS: HONORS LOUNGE

