

1990

Ocean Thermal Energy Conversion: (OTEC) Outlook for the Future

John M. Kroft
University of Rhode Island

Follow this and additional works at: https://digitalcommons.uri.edu/ma_etds



Part of the [Environmental Health and Protection Commons](#), [Oceanography and Atmospheric Sciences and Meteorology Commons](#), and the [Oil, Gas, and Energy Commons](#)

Recommended Citation

Kroft, John M., "Ocean Thermal Energy Conversion: (OTEC) Outlook for the Future" (1990). *Theses and Major Papers*. Paper 208.
https://digitalcommons.uri.edu/ma_etds/208

This Major Paper is brought to you by the University of Rhode Island. It has been accepted for inclusion in Theses and Major Papers by an authorized administrator of DigitalCommons@URI. For more information, please contact digitalcommons-group@uri.edu. For permission to reuse copyrighted content, contact the author directly.

OCEAN THERMAL ENERGY CONVERSION :
(OTEC)
OUTLOOK FOR THE FUTURE

By :
John M. Kroft

A PAPER SUBMITTED IN PARTIAL FULFILLMENT OF
THE REQUIREMENTS FOR THE DEGREE OF
MASTER OF MARINE AFFAIRS

Approved :  _____
Major Professor : Prof. Lawrence Juda

University of Rhode Island
Kingston, Rhode Island

1990

Abstract : The temperature differential between the tropical ocean surface and deep waters represents tremendous energy potential. Ocean thermal energy conversion (OTEC) systems represent an environmentally sound method to extract that energy resource. Included in this paper is a review of the history of OTEC, basic thermodynamic principles involved and major components of the system. The three basic types of OTEC systems are discussed, citing the various advantages and disadvantages of each. The resource extent and possible environmental impacts are examined from the U.S. perspective. After reviewing the conflicting ocean use interests involved, comparative cost calculations of energy types, and the secondary benefits of plants, projections for the future of OTEC facilities are given.

Table of Contents

<u>Section</u>	<u>Page No.</u>
I. Introduction and Historical Background	1-5
II. OTEC Thermodynamic Principles and Major Components	6-25
A. Basic Thermodynamic Principles	6
B. Major Components of OTEC Plants	6-18
1. Heat Exchanger	7-9
2. Turbines	9-10
3. Cold Water Suction Pipes	11-13
4. Support Platforms	13-18
III. OTEC System Types	18-25
A. The Open Cycle	18-21
B. The Closed Cycle	21-24
C. The Hybrid Cycle	25-25
IV. Resource Extent and Potential	26-30
V. Environmental Impacts	30-44
A. Atmospheric Impacts	31-34
B. Terrestrial Impacts	34-35
C. Marine Impacts	35-44
1. Redistribution of Oceanic Properties	36-40
2. Chemical Pollution	40-44
3. Structural Effects	44-45
VI. Conflicting Use Interests	45-48

VII. Comparative Cost Calculations of Energy Types	48-49
VIII. Secondary Benefits of OTEC Facilities	50-53
IX. Conclusion	53-57
References (Footnotes)	70-76

List of Figures

<u>Figure No.</u>	<u>Page No.</u>
1. Relative Potentials of Ocean Energy Sources	58
2. Barge Type OTEC Platform	59
3. Ship Type OTEC Platform	60
4. Spar Type OTEC Platform	61
5. Semi-Submersible OTEC Platform	62
6. Artist's Conception of OTEC Facility	63
7. Schematic of Open Cycle OTEC System	64
8. Schematic of Closed Cycle OTEC System	65
9. Schematic of Hybrid Cycle OTEC System	66
10. World OTEC Resource Extent	67
11. Gulf of Mexico Resource Extent	68
12. List of Ocean Uses	69

I. Introduction and Historical Background

The oceans of the world cover nearly sixty million square kilometers, equaling approximately 71% of the earth's surface. This huge body of water absorbs a tremendous amount of solar energy on an average day and for more than a century scientists have experimented with methods to extract some of that energy.

One of the earliest methods theorized to utilize that stored solar energy is what has become known as ocean thermal energy conversion (OTEC) systems. Ocean thermal energy conversion (OTEC) is a solar technology. It uses the temperature difference (ΔT) between the warm surface water and the cold water from the ocean depths to operate a thermodynamic cycle to generate electricity.

The ocean thermal energy conversion (OTEC) process was developed and proposed in 1881 by the French physicist, Jacques Arsene d'Arsonval. D'Arsonval proposed that the temperature gradient between the warm surface waters and the cold deep water in tropical oceans could be used to generate electricity [1]. To recover the stored solar energy represented by the temperature gradient, d'Arsonval designed a closed cycle conversion system (see fig.8, pg.65). The principle of operation of the system developed by d'Arsonval was fairly simple. Warm seawater was pumped into a heat exchanger

where it boiled a working fluid having a low boiling point, such as ammonia or Freon [2]. This working fluid, having changed to a vaporous state, is then used to drive a low pressure turbine. A second heat exchanger using the cold deep ocean water, condensed the working fluid which was then recycled through the system back to the first heat exchanger to again be boiled and repeatedly reused through the system.

In 1930, a French inventor and former student of d'Arsonval, Georges Claude, tested the validity of his mentor's theory. Operating in Matanzas Bay, Cuba, Claude succeeded in generating 22 kilowatts of power from an open cycle conversion plant (see fig.7, pg.64) [3]. However, more power was expended pumping the water through the heat exchangers than was in turn produced by the system. Due to the low pressure vapor developed, a large turbine would have to be used to gain maximum efficiency. Although the small size of Claude's turbine caused the system to be an economic failure, it proved the validity of d'Arsonval's theory that electricity could be obtained from ocean thermal energy.

Claude's next effort was a floating open cycle system installed on a cargo vessel anchored off the coast of Brazil. The experiment failed due to waves destroying the cold water suction pipe as it was being installed. Claude, who invested virtually all his own money in the failed venture, died bankrupt and never achieved his dream of

generating net power with an open cycle ocean thermal energy system [4].

The French government, influenced by Claude's efforts, continued the research on open cycle systems and in 1956 a 3 megawatt plant was designed to be built at Abidjan on the west coast of Africa. For a variety of reasons, including difficulties encountered in the deployment of the cold water suction pipe, the plant was never constructed [5].

Little effort was applied to the area of OTEC research until the worldwide energy shortages of the 1970's prompted renewed interest. The United States government's response to the Middle East oil cartel's oil embargoes was increased research in alternate energy sources to reduce America's dependence on foreign oil. One of the major alternate energy sources of interest was solar power, thus the formation of the U.S. Solar Energy Program in 1972. This program was sponsored by the National Science Foundation and was responsible for examining solar energy technologies capable of reducing our nation's dependency on unreliable foreign oil suppliers. Conclusions resulting from the program indicated six possible methods of extracting energy from the ocean: thermal gradients, salinity gradients, wave power, tidal power, hydro-electric and geothermal power [6]. Of the six methods of energy extraction, thermal gradients had the highest efficiency rating (see fig.1, pg.58)[7].

Naturally, research involving ocean thermal gradients received a high priority and in 1972 the first project to utilize that stored solar energy of the oceans began. Since 1972, scientists and engineers have studied and tested various thermal energy gradient systems and their component parts, including heat exchangers, turbines, cold water suction pipes and system support platforms.

It was nearly fifty years after Claude's initial efforts before scientists and engineers from the state of Hawaii and the Lockheed Aircraft Corporation succeeded in producing surplus electrical power from a closed cycle OTEC system. Similar in design to the system created by Claude, the plant named mini-OTEC was mounted on a barge moored about two kilometers off Keahole Point on the island of Hawaii [8]. Mini-OTEC operated sporadically for a period of four months and grossed fifty kilowatts while netting fifteen kilowatts of electrical power [9]. Mini-OTEC was not expected to achieve the ratio of net to gross power that would be required for a successful commercial plant venture. Instead, mini-OTEC's primary purpose was to provide a data base of information on heat exchanger thermohydraulics, environmental impacts, cold water pipe construction and deployment and systems operation [10].

While mini-OTEC was operating in 1979, scientists were building OTEC-1 on an old World War II T-2 tanker, also off

Keahole Point, Hawaii. The purpose of the OTEC tanker was to allow scientists to evaluate plant operation to test closed cycle heat exchangers of commercial size [11]. These heat exchangers were of the shell and tube type with seawater flowing through the tubes and the working fluid evaporating or condensing around the tubes within the outer shell [12]. The results gained from OTEC-1 included increasing the efficiency of heat exchangers through the reduction of bio-fouling and corrosion from seawater.

Some time after mini-OTEC and OTEC-1, the Tokyo Electric Power Company and the Toshiba Corporation built a closed cycle plant in the Republic of Nauru in the Pacific. This last field test of an OTEC system resulted in the successful, though intermittent, operation of a closed cycle plant using Freon as the working fluid. Between 1981 and 1982, the Nauru plant grossed 100 kilowatts of power with a net gain of 35 kilowatts over its period of operation [13].

Following the results of the Nauru project, the Department of Energy's OTEC purpose seemed to change from the direct promotion of commercialization of ocean energy technologies to the support of research that the private sector would be unlikely to undertake. This research involved the technological analysis of many of the individual system components comprising an OTEC plant.

II. OTEC Thermodynamic Principles and Major Components

A. Basic Thermodynamic Principles

The basic principle involved in the operation of an OTEC plant is the use of the differential temperatures of the oceans layers to heat a working fluid to a vapor to drive a turbine. This turbine in turn drives an attached generator, thereby producing electricity.

Due to the economic and performance characteristics of an OTEC system, power plants require a nominal water temperature difference (ΔT) of at least 20 degrees centigrade [14]. Temperature differences of this magnitude exist between ocean waters at the surface and at depths up to 1000 meters (3281 feet) in many areas of the world, particularly in tropical latitudes between 24 degrees north and south of the equator. In these regions, surface water temperatures typically range from 22-29 degrees centigrade (72-84 degrees F), while temperatures at a depth of 1000 meters typically range from 4-6 degrees centigrade (39-43 degrees F) [15]. This temperature gradient provides for a vast, relatively constant renewable resource for OTEC based power generation.

B. Major Components of OTEC

There are four major components associated with an OTEC plant : heat exchangers, turbine, cold water piping and the support platform.

1. Heat Exchangers

In general, heat exchangers provide an area for the transfer of heat, normally to change the state of a material from a vapor back into a liquid. The heat exchangers account for approximately twenty percent of the total cost of a closed cycle plant and the efficiency of the system is directly dependent on the efficiency of the heat exchangers [16].

The original OTEC plant designs, including mini-OTEC and OTEC-1, used the shell and tube type heat exchangers. However, recent research has developed a heat exchanger with a plate-fin design which increases the total surface area and thus, according to heat transfer theory, increases the rate and efficiency of the heat transfer. This type of heat exchanger consists of an array of parallel plates arranged so that one of them carries the cooling medium, seawater, the one next to it carries the working fluid, and so on throughout the apparatus [17]. The fins are located between the plates and contribute to the heat transfer rate by increasing the surface area. Research is continuing on both the shell and tube type and the plate-fin heat exchangers with the goal of developing an optimum design. A design that would reduce the required surface area of the heat exchanger and minimize the required cooling medium flow while improving the efficiency of heat transfer.

Heat exchangers are highly susceptible to damaging corrosion due to the seawater environment under which they must operate. The original heat exchangers used in OTEC-1 and mini-OTEC were constructed of corrosion resistant titanium. Unfortunately, widespread use of titanium is impractical due to its high cost. However, recent research has been conducted to improve resistance to corrosion. Numerous alloys are currently being analyzed, with brazed aluminum and copper nickel showing good promise [18]. Replacing titanium as the material of heat exchanger construction could reduce costs by as much as one third [19]. In addition to the material being used, the corrosion rate is also affected by its environment and the temperatures involved. The rate of corrosion varies based on the combinations of material and temperature with some materials performing better in the warm water "loop", while others hold up better on the cold water side of the system.

Biological fouling is another major problem associated with OTEC plants as it causes a reduction in the heat exchanger efficiency. Research has confirmed that bio-fouling will not be a problem for surfaces in the cold water loop of the plant, such as the condenser, since the biological actions are slowed by the cold [20]. However, for those surfaces exposed to the warm seawater, the bio-fouling is a significant problem. Chlorination, shown

to reduce and even prevent bio-fouling, may not be an appropriate solution due to its effect on the local environment even at low concentrations [21]. However, assessments of the effects of the chlorination process at a distance from the plant are difficult to make due to the complexities of seawater chemistry.

2. Turbines

The turbine, as the mechanism used to extract useful work from the system, is perhaps the single most important component of an OTEC plant. As with any turbine powered system, the OTEC plant turbine must be capable of accepting the motive force (low pressure steam of open cycle systems or relatively low pressure ammonia or Freon vapor of closed cycle systems) and extracting its energy to accomplish work. The turbine must be able to use the large volume of low pressure steam or vapor and efficiently operate at speeds capable of meeting required levels of power. The larger turbines in use today in conventional power plants are 4.5 meters in diameter and serve in the secondary, low pressure stage of the generating system [22]. These turbines are giants compared to the one meter diameter turbine Claude used in his open cycle system. The larger the turbine, the greater the amount of energy is extractable from the low pressure steam or vapor. Engineers at Westinghouse Electric Corporation foresee the use of a single large diameter

turbine as the most efficient use of the available energy in the low pressure vapor. They have hypothesized that an OTEC plant producing 100 megawatts of net power would require a turbine 43.6 meters in diameter [23].

Current technology can not support the large diameter turbine proposed by the Westinghouse engineers which would be exposed to tremendous stresses, thereby eliminating the use of metal alloy blades that are currently employed in conventional low pressure turbines. A possible solution to this problem may be achieved through the use of fiber-reinforced plastics. These plastics are strong, lightweight and easier to form into the required shape of the turbine blading. Westinghouse is in the process of designing a turbine with long slender composite blades made with fiber-reinforced plastics similar to those of helicopter blades. These blades would be twisted and properly curved like the blades of a traditional low pressure steam turbine [24]. However, since this system is still in the design phase, current turbine technology is probably the more feasible solution. By employing large, conventional technology, low pressure turbines in series operation, sufficient energy could be extracted from the steam or vapor. Construction materials would not need to be changed and a more proven design could eliminate possible costly surprises.

3. Cold Water Suction Pipe

For OTEC plants to operate, a large volume of cold water must be pumped from great depths to provide sufficient cooling flow through the condenser. For a 100 megawatt power output, a cold water pipe 2-5 meters in diameter would be necessary to provide the seawater to the condenser [25]. The tremendous length and size required of the cold water suction pipe makes the successful deployment of this component of an OTEC plant extremely difficult. In 1929, following two unsuccessful attempts, Claude deployed a cold water steel suction pipe 1.6 meters in diameter and two kilometers long, a feat which was not successfully repeated until nearly forty years later [26]. It was at this time when mini-OTEC and OTEC-1 successfully deployed pipes constructed of polyethylene. These were, however, shorter than those required for a shore based OTEC facility.

In 1988, at Hawaii's Ocean Science and Technology Park, the U.S. Department of Energy and others successfully installed a 1.0 meter diameter, 2060 meter long, high density polyethylene pipe, capable of delivering approximately 13,318 gallons per minute of cold water from a depth of 700 meters [27]. The mechanical forces and stresses acting on a length of pipe greater than 1500 meters in length are excessive and complex. The additional hazards which the pipe will be subjected to in the marine environment merely

exacerbate the problem. There are currently many groups investigating designs, construction methods and deployment techniques to determine the best and most economical combination for use with OTEC systems.

In 1986, the Department of Energy completed an 8 foot diameter, shallow depth, cold water pipe in Hawaii. Later that same year, the Energy Technology Engineering Center (ETEC) conducted the at-sea testing of a 70 foot section of an 8 foot diameter cold water suction pipe, exposing it to the winter storm season in order to develop a data base on the impact of waves and currents upon it [28]. During the same period, the Solar Energy Research Institute (SERI) evaluated the viability of a soft cold water pipe and performed a design, stress and material strength analysis of in situ pipe loads. A reinforced membrane for the pipe wall and submerged pumps and motors which permit pressurized operation of the pipe was also developed and tested. Additionally, a buoyancy distributing anchor was developed to allow low risk deployment of the system [29]. Reducing the risk of deployment of the cold water suction pipe is a critical area of endeavor, for it is one of the most difficult elements of OTEC plant construction. This is demonstrated by the difficulties experienced by Claude when the cold water suction pipe he was deploying was lost when it broke off and sank in 500 meters of water [30].

G.L. Dugger proposed that a cold water pipe for an OTEC plant in the tropics, where currents are below 1 knot, could be constructed of simple double-walled aluminum material. However, for plants located in ocean areas with strong currents, the pipe would be better suited if constructed of high density polyethylene [31]. Polyethylene is flexible, yet strong enough to withstand the forces connected with strong currents or rough seas. Also, it has been evident since Claude's initial efforts that the cold water suction pipe will have to be very large, with a diameter of approximately 2.5 meters and a length of from 1000 to 1500 meters. To prevent excessive movement of the pipe while it is being deployed, a buoyancy distributing anchoring system can be used to control the buoyancy of the cold water pipe. A change in buoyancy will occur when water starts seeping into the void areas of the pipe. In order to maintain a constant freeboard, variable ballast is provided to compensate for the potential increase in the weight of the cold water pipe [32].

4. Support Platforms

OTEC plant support platforms of the future will have to be designed to conform to the peculiarities of the local area and ocean environment where they are to be stationed. Further, if the area of operation supports, a platform could be eliminated and the plant built directly on the seabed in

shallow water adjacent to land or directly on the shore.

Conforming to local peculiarities would require an OTEC plant platform being used in the Gulf Stream to possess anchoring and sturdy construction if it is to be able to withstand the strong currents and frequent hurricanes common to the area. In contrast, a plant located in the Atlantic Ocean between approximately 10 degrees north and 10 degrees south latitude, could be constructed of lighter, cheaper material and would not have to be anchored as securely because the winds are normally less than 25 knots, currents are less than 1 knot throughout the vertical column and the hurricane danger is minimal [33]. Much of the knowledge gained from research and practical application of oil rig platforms can be readily transferred to OTEC platforms. Oil rig platforms have already been exposed to the same natural conditions to which OTEC platforms would be subjected and the same types of operations take place on both.

In 1975, Roderick Barr proposed four basic platform designs for OTEC systems [34] while a fifth alternative was developed and tested by Alfred Simenson [35]. The five basic platform designs include :

- a. Barge or disc type platform
- b. Ship based platform
- c. Spar type platform
- d. Semi-submersible type platform (includes several variations)
- e. Tuned sphere stable platform

At the present time, only the land based (Claude in Cuba), barge type (mini-OTEC) and the ship type (OTEC-1) platforms have been employed with an OTEC system. Prior to the implementation of other types of platforms, many factors such as their ability to withstand storms and accompanying high seas, maneuverability, cost and capability to deliver power to the destination of use must be researched and considered.

The barge and ship type platforms (see figures 2 and 3, pp.59 and 60) have many common characteristics with the only significant difference being the ability of the ship to "graze" slowly through the water to maximize the temperature differential and minimize any environmental impacts to the local area. As examined by Robert Douglass, some of the characteristics common to both include the following [36] :

- a. Relatively easy construction using proven technology or with the option to use existing vessels such as was done with OTEC-1.
- b. Reliable support of the cold water suction pipe through the use of a gimbal apparatus which provides for a point of positive yet pivoting attachment.
- c. Provide a base of operation with favorable habitability and working conditions.
- d. Allows for ease in transfer of crew, equipment and consumable supplies.

- e. Ease of maintenance of vessel/barge structure due to ability to detach and dry dock for repairs.
- f. Components of OTEC plant are easily accessible for maintenance and repair.
- g. Ability to detach or reattach vessel/barge from the cold water suction pipe for required emergency movement or for periodic maintenance.

The only significant disadvantage of vessel/barge type platforms lies in their unfavorable sea-keeping ability when compared to other more stable designs.

In contrast to the vessel and barge, the spar platform (see figure 4, pg.61) possesses excellent sea-keeping capabilities but is predicted to be the most difficult to build and maintain [37]. In the evaluation of platform design by Douglass, the spar type platform had the lowest overall potential for success. In addition to the difficulties encountered in building and maintaining, it was predicted that the platform would not reliably support the cold water suction pipe nor would it be conducive to additions or modifications at some point in the future. Various other problem areas have been identified during research and experimentation which would have to be resolved but no fatal flaws have yet been identified [38]. Therefore, the spar type is still a viable candidate with potential for future use.

The fourth type OTEC platform evaluated by Douglass was the semi-submersible structures and their variants. The semi-submersibles were ranked ahead of the spar type platforms and given marks nearly equal to those received by the ship and barge platforms. Semi-submersibles are moored to the bottom but allowed to float at some median depth below the surface (see figure 5, pg.62). This characteristic affords excellent sea-keeping ability by being positioned below the wave action of the surface waters and reduces the length of the cold water suction pipe.

The tuned sphere is something of an anachronism in that it is merely a floating sphere containing all the OTEC plant components. Based on research and experimentation utilizing a scale model, Simensen has determined that the tuned sphere platform would be an efficient hull form for housing an OTEC plant [39]. However, the sea-keeping ability of the tuned sphere is significantly reduced following attachment of the cold water suction pipe. It appears that the most effective OTEC system platform will be a hybrid, combining the best characteristics of the ship, barge type and submersible platform designs. The semi-submersible type had the definite advantage of being free from the large platform forces due to waves, surface currents and winds. The surface ship or barge is affected by these forces but superior to the semi-submersible in operation, maintenance and cost [40].

Figure (6) shows an artist's conception of a possible OTEC facility of the future composed of a combination of features from both the barge and semi-submersible platforms [41]. Additionally, this type of platform could also be maneuverable through the directional discharge of the used water.

III. OTEC System Types

Power generation can be achieved with two basic types of thermodynamic power cycles converting the stored solar thermal energy to electrical energy : (1) closed cycle, and (2) open cycle. A third type which will also be considered is actually a combination of both the closed and open cycles and is referred to as the hybrid cycle [42].

A. The Open Cycle

Claude was the first to operate an open cycle OTEC plant and today those same principles are being used to attempt to obtain cost competitive renewable energy from the sea. The process of generating electricity using an open cycle OTEC plant is relatively simple, as shown by the schematic of figure (7), page 64.

In an open cycle system, warm surface seawater is the working fluid. As indicated in figure (7), the warm

seawater of the surface layer of the ocean is pumped into a flash type evaporator chamber which is maintained under a vacuum sufficient to boil the 22-29 degree centigrade seawater. The resulting change of state of the seawater produces a low pressure steam which is used to power the turbine. The turbine in turn is connected via gearing to an electric generator. The steam exiting the turbine casing is drawn into the condenser chamber where the steam once again changes state back into water. The cooling medium of the condenser chamber is the cold seawater (4-6 degree C) which is pumped from the ocean depths. The condensing chamber provides a dual purpose for the system. First, it condenses the exiting steam, preventing the low pressure steam from filling the turbine casing causing overheating of the blading and inefficient turbine operation due to drag. Additionally, the condensing chamber can be of a shell and tube type design which would ensure separation between the exiting steam and the seawater condensing medium, producing freshwater as a by-product of the operation.

The freshwater by-product of the operation is a result of the initial boiling of the warm surface seawater vaporizing into steam. As the seawater flashes into steam, the chemical constituents such as sodium and chlorine ions are left behind. This results in the production of freshwater when the steam is condensed back into a liquid.

In many tropical areas where OTEC plants could be placed in operation, freshwater is at a premium and could provide a very important additional income for the system operator. Current estimates indicate that an OTEC plant designed to produce 10 megawatts of power could supply enough freshwater, approximately 5 million gallons each day, to support a city of 10,000 to 20,000 people [43].

The production of freshwater as an operational by-product is only one of the advantages of the open cycle OTEC plant design. First, by using seawater as the working fluid it eliminates the possibility of contaminating the marine environment with toxic fluids such as ammonia and Freon which are used as the working fluids in closed cycle OTEC plants. In the event of an ammonia or Freon leak in a closed cycle system the environmental damage resulting could be significant. Second, an open cycle system could use a less expensive, direct contact type heat exchanger wherein the exhausting working fluid mixes with the condensing medium rather than the shell and tube type which keeps them separate. If there is no desire to retain the freshwater produced in the system, then a direct contact heat exchanger can be employed, resulting in a construction cost savings. Additionally, direct contact heat exchangers could be made of lower grade materials resulting in even further construction cost savings [44].

In contrast with all the aforementioned advantages there are some distinct disadvantages and technological problems. One of the major problems is that the low pressure steam produced in an open cycle OTEC plant would, based on basic turbine theory, require a much larger size turbine to extract the available energy. Coupled with the large turbine, a large condensing chamber would also be required in order to condense the expended volume of the exhausting low pressure steam [45]. Another disadvantage associated with the open cycle system is the release of non-condensable gases from the low pressure seawater in the initial flash evaporator chamber. The resultant release of non-condensable gases would impair the effective operation of the turbine and could ultimately result in a loss of vacuum in the condensing chamber or overheating of the blading, either of which would require shut down of the turbine.

B. The Closed Cycle

The closed cycle OTEC system is similar in many respects to the open cycle system. The major difference between the open and closed cycle systems, as shown in figure 8, page 65, is that in the closed cycle the warm surface seawater is used to vaporize a working fluid contained within tubing in the evaporator chamber. In the

open cycle system, the warm seawater is vaporized and is the working fluid of the system. The working fluid of the closed cycle system, typically ammonia or Freon, must be a liquid with a very low boiling point. The working fluid, once vaporized in the flash chamber evaporator is used, as in the open cycle, to drive the turbine which in turn drives the generator to produce electricity. Upon exiting the turbine the expanded ammonia or Freon vapor is drawn into the condenser where it changes state back into a liquid and is then reused in the system. Thus the name closed cycle system; the working fluid never leaves the system and is reused through the thermodynamic process.

The majority of OTEC research that has been conducted has focused on closed cycle systems which include the experimental OTEC-1 and mini-OTEC efforts previously discussed. When OTEC research intensified in the 1970's, the technological base of information was much greater for the closed cycle plant than for the open cycle system [46]. Robert H. Douglass emphasized this fact when he spoke about how the closed cycle was chosen as the primary vehicle of research : "We were given no charge as to the cycle to select. However, the availability of ready technology . . . of the closed, in contrast to the relative innovation needed for the open cycle led us to the former. If we were to adopt a system dependent on our

innovations, we might fall on our faces hard. So we decided to go with the closed cycle engineering technology we believe to be available here and now [47]."

Apparently, when the OTEC effort began, there was a political push to produce an operational ocean thermal gradient system. The closed cycle system was selected for research purposes because more information was available regarding its components, thereby improving the chances for a successful experimental effort. Once net electricity was produced, the organizations involved in the research probably felt they would be awarded more funding to continue their projects. With additional funding, the research could also be expanded to include the open cycle and its components.

The greatest advantage of the closed cycle system is the relatively greater pressures developed due to the low boiling point of the working fluid (ammonia or Freon). The higher pressures allow the closed cycle system to use a smaller turbine and reduces the problems associated with low pressures which were outlined in the section on open cycle systems. Another advantage of the closed cycle system lies in its ability to produce certain by-product chemicals during operation [48]. Ammonia, the working fluid of the system, can also be produced by the plant. Other products which could also be produced by a closed cycle plant include : magnesium, synthetic oil, methane, methanol and liquid

hydrogen. However, Dugger, et al., concludes that the costs associated with the production of these chemicals would be greater than the cost of production in a conventional chemical plant [49]. As the technology of the plants increase, the production costs of these chemicals may be reduced to the point of viability. The final advantage of closed cycle plants is simply the higher level of technology and information available pertaining to the system and its individual components.

The major disadvantage of the closed cycle plant lies in the danger associated with the possibility of a leak in the system allowing the hazardous working fluid to enter the environment. Ammonia or Freon, if allowed to enter the environment, would produce significant levels of damage. The second notable problem of the closed cycle plant is the higher construction costs, particularly in the heat exchangers of the condensing section of the system. The most significant disadvantage of the closed cycle system may be its inability to produce desalinated water as a by-product. Most authorities agree that the most practical near future employment of OTEC plants will be to supply power for isolated tropical island areas. In the majority of cases, these islands are also deprived of sufficient quantities of potable water. If an OTEC plant were to be used in such an area, an open cycle system would be more appropriate due to its ability to produce freshwater as a

by-product of operation.

C. The Hybrid Cycle

The hybrid cycle system is, as the name implies, a combination of both the open and closed cycle systems. The principles of operation, however, remain the same. The warm surface water is drawn into a flash type evaporator chamber where it boils. The steam produced is then utilized to heat the low boiling point working fluid into a vapor. The vaporized working fluid is then used to turn a turbine/generator to produce electricity (see fig.9, pg.66). Once the energy has been extracted and work produced, the working fluid is recondensed by the cold deep ocean water and sent back to the beginning of the cycle. The hybrid cycle system is similar to a nuclear power plant, in that there is an inner loop (warm surface water/water heated by radioactive material) and an outer loop (ammonia or Freon/water heated by radioactively heated water).

The hybrid cycle system, being a combination of the open and closed cycles, shares many of the advantages and disadvantages associated with those systems. The hybrid cycle plant can produce freshwater as a by-product and develops a higher pressure vapor than open cycle systems allowing for the use of a smaller size turbine. However, the same environmental dangers associated with the closed cycle systems use of ammonia or Freon exist for the hybrid cycle as well.

IV. Resource Extent and Potential

The success of OTEC plants in the future depends on numerous variables. One of these variables is the extent of the available resource which can be profitably utilized. As mentioned previously, the operational and design characteristics of an OTEC system require a minimum nominal water temperature difference (ΔT) of 20 degrees centigrade. The greater the temperature differential, the greater the available energy and resultant efficiency of the OTEC system. This requirement for a minimum temperature differential of 20 degrees centigrade creates one of the greatest limitations to OTEC technology utilization. A temperature differential of at least 20 degrees centigrade occurs in only limited geographical locations around the globe, thereby limiting the total potential of OTEC plant employment.

For areas to achieve a temperature differential of at least 20 degrees centigrade, two physical factors must overlap. The first factor is a tropical area to warm the surface waters adequately. The second factor is water of sufficient depth to yield water cold enough to achieve the proper temperature differential [50]. Figure 10, page 67, shows those areas where the two physical factors overlap to

produce an area with the potential to provide power through the use of an OTEC power plant [51].

Another variable affecting the potential of an area once the requisite temperature differential is present, is the distance of the area from the intended site of use. The distance from the site of use will have economical and technological implications for OTEC plants. If the distance from the use site is too great, the electric losses in the cable and the actual cost of the cable become prohibitive. Current estimates have established the maximum acceptable distance, based on cable considerations, is approximately 180 nautical miles [52].

The final factor which, for the present time at least, limits the use of the available resource is the depth of the water. As mentioned previously, a depth of approximately 1000 meters is required to achieve the necessary temperature differential. However, areas with depths greater than 2000 meters which are suitable in other respects, can not be used due to the present limits of mooring technology [53]. This figure applies to floating platforms and is considerably less for other types of rigidly anchored systems.

From the U.S. perspective, the areas which have the potential to provide OTEC power by meeting the aforementioned criteria include the islands of Hawaii, Puerto Rico, other territorial possessions and sections of

the Gulf of Mexico. Of all of these, the resource potential of the Gulf of Mexico is definitely the most potentially lucrative and has therefore been more fully researched. However, it is difficult to find two research efforts that agree on the actual power potential of the Gulf of Mexico resource, with estimates varying between 2 and 2000 gigawatts (GWe) of electricity [54].

Although Hawaii is definitely in the thick of OTEC research, the most probable large scale use of the OTEC resource in the future will occur in the Gulf of Mexico. By taking the various factors such as depth and distance into account, the resulting area in the Gulf of Mexico potentially available for exploitation is indicated by figure 11, page 68.

An interesting characteristic of the Gulf of Mexico which adds a complication to the possible exploitation of the thermal resource is the presence of a loop current. The loop current enters the Gulf through the Yucatan Straits, bends sharply to the right and exits through the Straits of Florida [55]. It is this loop current with an average width of approximately 300 kilometers from which the greatest thermal resource could be derived [56]. The complication which is added by the currents presence lies in the fact that it migrates slightly in response to seasonal changes [57]. An OTEC plant site would have to be located to take

continual advantage of the increased thermal energy of the loop current to maximize plant efficiency and therefore productivity.

Another physical quirk of the Gulf of Mexico affecting siting of an OTEC plant is the presence of "cold tongues" of water [58]. These cold tongues of water migrate seasonally as does the loop current and would have to be avoided in the siting of an OTEC plant [59]. In any event, much research is currently being conducted by numerous agencies regarding the physical characteristics to try to optimize the siting of OTEC plants in the Gulf of Mexico.

The strip of potential OTEC locations indicated in figure 11, was developed by considering water depth, distance from shore and the area of the loop current. Once a location has been fixed, the next consideration affecting the total future extent of the resource is the spatial distribution of multiple OTEC plants. The relative location of one plant with respect to its neighboring plant can result in an accelerated depletion of the resource [60]. A depletion of such rapidity could theoretically negate the potential productivity of all the plants in the area. Pei estimated that the spatial distribution of plants would have to be on the order of 5500 meters per 100 megawatts of electrical production [61].

As mentioned previously, the resource potential of the

Gulf of Mexico has been estimated by numerous researchers and has ranged from 2 to 2000 gigawatts of electricity. The factors addressed in this section which affect that estimate include :

- a.) Depth of water (minimum and maximum)
- b.) 180 nautical mile distance from shore (or less)
- c.) Area affected by loop currents and cold tongues
- d.) Spatial distribution of plants

Based on the integration of these four factors, the most accurate estimations of the resource potential is on the order of 10 to 30 gigawatts of electricity [62]. This is a significant potential since the entire southern United State's actual demand for 1984 was approximately 114 gigawatts of electricity [63].

V. Environmental Impacts

The majority of all energy producing systems have negative environmental impacts associated with them. Oil refineries pollute the air, oil spills contaminate the sea and acid rain is attributed to coal burning. Nuclear power plants such as Three Mile Island and Chernobyl have released radioactive material into the atmosphere. Of all the possible energy producing methods, the various forms of solar power seem to be the most environmentally safe. Even

though solar power seems to be the safest method of producing energy, operation of an OTEC plant could have negative environmental effects. The broad areas of the environment which must be considered prior to placing an OTEC plant in operation are the atmospheric impacts, terrestrial impacts and marine impacts.

A. Atmospheric Impacts

An OTEC facility will affect the atmosphere due to two factors: (1) ocean surface cooling, and (2) release of carbon dioxide [64]. Ocean surface waters are cooled when the huge volume of cold water necessary for condensation of the working fluid is discharged into the surrounding surface waters. This discharge results in a lowering of the average surface water temperature in the area adjacent to the OTEC plant. With the recent advances in climatological research, it is believed that sea surface temperature changes of less than one degree centigrade can create fluctuations in the climatic processes of the atmosphere [65]. However, it is believed that this sea surface temperature change must occur over a large ocean area before its effects are felt [66]. The OTEC-1 project caused a decrease of only .4 degrees centigrade below normal within a few hundred meters of the plant [67]. However, long range study is required on the effects of OTEC-caused climatic changes before any

conclusions can be drawn. The El Nino phenomena which occurs off the western coast of South America is similar in nature to the conditions which would occur in the vicinity of an OTEC plant. By the study of EL Nino, the results may lead to insights into the effects of an OTEC plant. It must be remembered though that the effects of El Nino are on a much larger scale than an OTEC plant. It should also be recognized that by designing the plant to have the cold water discharge pipe below the thermocline, the degree of surface water cooling would be significantly reduced, thereby reducing the climatic effects [68].

The second atmospheric impact will result due to the release of carbon dioxide [69]. The operation of an OTEC plant makes use of large volumes of cold water from the depths which is rich in carbon dioxide. As the cold water is brought to the surface the pressure exerted upon it is decreased and its temperature increases. Based on the principles of Henry's Law of dissolved gases in solution, the decreased pressure and increased temperature both combine to release the carbon dioxide from solution. The result is the release of carbon dioxide into the atmosphere.

Carbon dioxide being released into the atmosphere is one of the most significant environmental problems of today and is the cause of the greenhouse effect. Basically, the greenhouse effect, through the trapping of certain light

waves, causes an increase in the earth's average temperature (global warming). The Environmental Protection Agency predicts that by the year 2040 the current trends in carbon dioxide emissions will cause a 2 degree centigrade warming of the atmosphere [70]. This rise in temperature could cause widespread significant changes in patterns of precipitation and increase sea level dramatically.

Presently, automobiles and coal fired power plants contribute large amounts of carbon dioxide to the atmosphere. Sullivan and his associates estimated that a typical 40 megawatt coal fired power plant produces more than four times that of an OTEC plant of equal power output [71]. Other more conservative estimates on carbon dioxide release range from two to three times that of a coal plant. Thus, the volume of carbon dioxide released by an OTEC plant is considerably less for an equal power output. Additionally, if the cold water is discharged at a greater depth much of the carbon dioxide would go back into solution and therefore not escape to the atmosphere.

One final adverse atmospheric impact would result from the working fluid of a closed cycle OTEC plant (ammonia or Freon) escaping to the atmosphere. Although a closed cycle, there will undoubtedly be some leakage to the atmosphere. Also, during initial plant start-up charging some may be lost and through normal maintenance the system will have to

be purged periodically. All these instances of escaping ammonia or Freon gas will result in some degradation of the atmosphere, dependent on the amount discharged and the location of the plant.

B. Terrestrial Impacts

The terrestrial environment would be the least affected ecosystem in the event of the widespread use of OTEC plants. If the OTEC plant were of the land based type, the typical impacts resulting from a major construction project would be incurred at the chosen site. Those impacts could carry over into the near-shore marine ecosystem and could include stripping of land vegetation, construction run off and increases in coastal water turbidity. The magnitude of these various impacts would depend on the care exercised during construction and the specific site location.

In addition to the aforementioned impacts, certain secondary impacts such as increased tourism and industrial growth in the adjacent area could result. These secondary impacts would lead to further impacts in the form of increased support service activities and infrastructure of the community. The proper implementation of an OTEC plant requires construction which would minimize pollution effects on the surrounding environment and simultaneously be constructed such that it does not excessively interfere with the local economic infrastructure.

The possible climatic impacts initiated by changes in the ocean surface water temperature discussed previously as an atmospheric impact would naturally have an affect on nearby land masses. The significance of the impacts resulting from the climatic changes would be dependent on the magnitude of these changes.

C. Marine Impacts

The marine environment will undoubtedly incur the greatest number and degree of impacts as a result of OTEC plant siting. The Ocean Thermal Energy Conversion Environmental and Resource Assessment Program is that section of the Department of Energy which is tasked with determining what environmental impacts would occur through operation of an OTEC plant. Several environmental impact assessments have been completed, including those necessary to permit operation of OTEC-1 and mini-OTEC. From the research efforts of the OTEC Environmental and Resource Assessment Program and the various impact assessments, a base of information has been developed. The three areas of impacts within the marine environment which researchers have established include :

1. Redistribution of Oceanic Properties
2. Chemical Pollution
3. Structural Effects

1. Redistribution of Oceanic Properties

The redistribution of oceanic properties is the most significant and potentially hazardous aspect of OTEC plant operation and is a major environmental concern [72]. Because large quantities of cold deep water and warm surface water are pumped to the heat exchangers, many parameters such as temperature, salinity, density, dissolved oxygen, nutrients, carbonates, particulates and so forth will all be modified by mixing with the ambient ocean water in the area of discharge [73]. The mixing of any or all of these components causes changes which could be detrimental to a variety of macro and microorganisms in the affected areas. Another area of ocean water mixing occurs as the cold water discharge plume, due to its greater density, sinks back to the lower levels. Here too the possible effects on the local ecosystem could have further detrimental impacts on indigenous organisms. Also, as mentioned previously, the ocean water mixing causes a decreased water temperature in the immediate area of the OTEC facility which could cause localized atmospheric changes.

a.) Artificial Upwelling

An environmental impact related to the redistribution

of oceanic components which may eventually be considered a positive side effect is the "artificial upwelling" occurring in the immediate region of the OTEC plant operation. The cold water being transported to the surface from the ocean depths contains high concentrations of nutrients and minerals [74]. The discharge of this cold, nutrient-rich water to the surrounding warm surface water could enhance biological productivity, just as natural upwelling off the coast of Peru increases biological activity.

The world population's increasing requirement for food may be partially satisfied by the increased biological production which would occur in areas adjacent to OTEC plant discharges. The protein production currently obtained from the oceans is small, accounting for only 5-10% of the total world consumption [75]. The total fish production of the oceans, which is closely related to the total biomass production varies widely in different oceanic areas. The open ocean, with 90% of the surface area of the world's oceans produces only 0.7% of its fish, while the coastal zones with 9.9% of the ocean area produces 54% of the total catch [76]. However, the upwelling regions of the world, comprising only 0.1% of the total area, account for 45% of the total catch [77].

The upwelling areas, as found off the west coast of South America, are tremendously productive throughout the range of biomass, resulting in huge fish catches in relation

to area. "Artificial upwelling", as with natural upwelling, uses sunshine and nutrient-rich deep water as the raw materials to produce protein laden biomass. It is estimated that the discharge of cold nutrient-rich water into the surface layer would increase the existing nutrient level by 300% within a 260 meter radius of the plant's discharge, and create up to a 1500% increase in the phytoplankton population and a 540% increase in herbivores [78].

The protein production potential of upwelling zones exceeds that of most agricultural systems per unit area and as an added benefit is not as dependent on petroleum products for fertilization and production factors [79]. Thus, OTEC plants producing "artificial upwelling" areas could substantially increase local fish catches thereby helping to satisfy the world's increasing demand for protein sources.

In conjunction with the advantages of the "artificial upwelling" areas are certain disadvantages associated with the increased biomass productivity. The overall operating efficiency of the OTEC facility is decreased as a result of the higher number of organisms in the immediate vicinity. These disadvantages can be grouped into three categories, biofouling, impingement and entrainment.

Biofouling is a term to describe the action of both micro and macroorganisms attaching to the water side surface of the plant systems. This is a particularly significant

problem when the attachment occurs on the internal surfaces of the plant's heat exchangers, resulting in a lower heat transfer rate and a subsequent decrease in efficiency. Lower efficiency means lower productivity of the plant and lower profits of operation. It has been proven in Naval propulsion plants that a 50 micrometer (0.00197 inches) layer of growth will reduce heat transfer efficiency by up to 25% [80]. There are various possible solutions to either eliminate or at least reduce the effects of micro or macrofouling which will be discussed later.

The second problem intensified due to "artificial upwelling" and the resultant increase in biological productivity is impingement. Impingement occurs when organisms are sucked onto the intake piping screens of either the cold or warm water suction pipes. The screens are to prevent intake of larger organisms causing a clogging of the heat exchanger tubing. Organism impingement on the screens causes a decreased volumetric flow rate of water through the system. Organisms most likely to impinge on the inlet screens are small fish, macroplanktonic crustaceans (shrimps) and cephalopods (squids, octopus, etc.) which are too small to resist the in-flow current yet too large to pass through the approximately 2.5 centimeter screen openings [81].

The third and final problem associated with the

"artificial upwelling" and increased organism concentrations is entrainment. Organisms entrained in the seawater which passes through the heat exchangers will experience a near 100% mortality rate [82]. Those organisms will be subjected to impact forces, abrasion, rapid temperature fluctuations, changes in oxygen, nutrient concentration, salinity and so forth. Entrainment at the cold water intake pipe will undoubtedly be relatively low since biomass at depths of 1000 meters is minimal. However, entrainment at the warm water intake will be high and could reduce the local biological community populations [83]. Depending on OTEC plant site location, the significance of the impact will vary. For example, a near shore site could entrain high numbers of larvae from spawning areas vital to maintenance of the adult population. Mortality of larval populations could damage or at least negate possible gains in certain species productivity resulting from "artificial upwelling".

2. Chemical Pollution

The second group of impacts affecting the marine environment are those associated with chemical pollution. Impacts resulting from chemical pollution would no doubt be much more immediately damaging, particularly in the local vicinity of the OTEC plants. A review of the literature indicates chemical pollution could result from the following four sources during OTEC plant operation and/or construction :

- a.) Oil Pollution
- b.) Biocide Release
- c.) Working Fluid Release
- d.) Trace Corrosion Product Release

a.) Oil Pollution

Oil pollution could result from OTEC plant operation in small quantities during routine lubrication maintenance activities or in large quantities if a proposed construction technique is used. A large oil spill could occur during the construction phase deployment of the cold water pipe. A proposed cold water pipe deployment technique consists of filling a steel insert within the pipe with over 260,000 gallons of oil for buoyancy and floating the pipe to the site of deployment [84]. To sink the pipe once in position, the oil would be pumped from the pipe to a barge. If a spill occurred, there would be severe damage to the local environment. As illustrated by the difficulties encountered by Georges Claude in 1930, the potential for natural disaster due to the elements, coupled with the innate mechanical difficulties make deployment of the cold water pipe a truly unpredictable evolution. The high potential for disaster indicates that the use of an oil flotation system for cold water pipe deployment would not be the most prudent solution to the problem.

b.) Biocide Release

The intermittent injection of chlorine or other biocide has been shown to reduce the problem of biofouling on OTEC heat exchanger surfaces [85]. The effects of discharging chlorine or other biocides into the marine environment are not yet fully understood. However, it is likely they would be negative. The Environmental Protection Agency has taken the initiative to limit the amount of chlorine discharged to 0.2 milligrams per liter during a two hour period each day [86]. If intermittent chlorination fails to reduce the fouling then chemical or mechanical cleaning would be required. Chemical cleaning would be more hazardous to the environment while mechanical cleaning would be more expensive.

c.) Working Fluid Releases

A working fluid (ammonia or Freon) release could occur on a closed cycle OTEC plant causing damage to the environment. A 50 megawatt OTEC plant would contain over 350 tons of ammonia, a major volume in the event of a material failure to the system [87]. A release of the working fluid of that magnitude would be highly toxic, causing the large scale extermination of biota in the near vicinity of the plant with gradually decreasing effects radiating outward. The distance and degree of these effects would be strongly dependent on prevailing winds and ocean currents. If an ammonia release occurred, it is estimated

that approximately 40% would enter the atmosphere, while the remaining 60% would be dissolved in the surrounding ocean water [88].

d.) Trace Corrosion Product Release

The release of trace constituent elements could also lead to potentially toxic effects on the marine environment. Aluminum, titanium, copper and lead are major metals involved in the production of heat exchangers and piping systems [89]. When exposed to the corrosive effects of seawater these materials would release toxic constituents [90]. Although the toxic effects of certain trace elements such as mercury have been extensively studied and are well documented, the effects of the majority of other metals is only partially understood. Further research is necessary in order to determine what concentrations of trace metals present a hazard and any combinatory effects they present.

Closely related to the release of trace metals through corrosive processes is the release of certain salts of heavy metals from protective coatings. OTEC plant water side surfaces could be protected through the use of coatings that contain a soluble toxic compound. Salts of heavy metals such as copper, mercury and zinc are the most commonly used toxins to prevent organisms from attaching to surfaces. These coatings are commonly used on U.S. Naval vessels to prevent hull growth which reduces ship speed as growths in

OTEC plant surfaces would decrease system efficiency. The release of toxic salts of heavy metals would degrade the environment gradually over time as they are solubilized, with more concentrated releases during maintenance repainting periods.

3. Structural Effects

An OTEC plant located in the ocean, either submerged or floating on the surface, will act like an artificial reef and provide habitat for a variety of marine life. Aquatic organisms tend to congregate around objects in the water. The most likely explanation for this behavioral characteristic is based on food supply and cover. The larvae of many aquatic species require a surface for attachment during certain stages of their life. Smaller fish which feed on the larvae will congregate around structure to take advantage of the available food source and also to use the protection provided to avoid predatory larger fish. The larger fish will naturally congregate around structures for the same reasons as do the smaller fish species. The increased number of biotic organisms due to the attraction of the structure itself only compounds the operational problems of biofouling, impingement and entrainment. However, it must be remembered that the effects of "artificial upwelling would no doubt cause a much more significant increase in biota in the vicinity of an OTEC facility than the attraction of the structure itself.

In addition to the attraction effects of the structure for aquatic organisms, an OTEC plant may also produce a nesting attraction for certain species of sea birds. While the structure may attract certain species, others may be repulsed. This could be particularly significant in the case of some shore bird's nesting behavior being adversely affected by a shore based or near shore facility.

VI. Conflicting Use Interests

Arvid Pardo, during the Law of the Sea negotiations in 1975, stated that, "Ocean space - the surface of the seas, the water column, the seabed and its subsoil - is by far the largest and most valuable region of our planet which still awaits full utilization by man" [91]. Since 1975, when Pardo made that statement, the utilization of the oceans has increased and will continue to do so in the future. As has been witnessed in the oil industry, increases in the technology of platforms or drilling has enabled greater exploitation at increasing depths. Intensification of existing ocean uses, coupled with the introduction of new uses as technology increases, only compounds the present conflicts between interests vying for use of the available ocean space. The intensified exploitation permitted by advances in technology can be applied to all existing uses of ocean space and will also hold true for OTEC plants in the future.

At the present time there are a multitude of ocean users, with a multitude of variations in the intensity of use and exclusivity of that use. For example, the intensity of petroleum exploitation varies tremendously based on geographic location but does not require exclusive control of an area of the ocean. However, military exercise areas mandate exclusive control of an area but are not intensive users, while waste disposal areas by the very nature of that activity create relative exclusivity. Both the intensity of a particular use and the compatibility of various uses must be considered in attempting to resolve conflicts between differing activities.

Ocean uses are generally divided into the two broad categories of consumptive (extractive) and nonconsumptive (nonextractive), with consumptive uses being further subdivided into renewable and nonrenewable uses [92]. The list on page 69 displays some of the variety of interests presently using the oceans.

Due to the variety of interests, many ocean uses could be in conflict with others. OTEC plants, since they will be similar to oil drilling platforms in physical characteristics will cause conflicts similar to oil rigs. OTEC facilities siting requirements (sufficient ΔT and within approximately 180 nm of use site) will result in increased conflicts with navigation since the highest areas

of traffic and highest incidence of collisions are near shore where OTEC plants would be located. Conflicts between OTEC and fishing will arise due to the platform and suction pipes interfering with drag type fishing gear and in the potential disruption of traditional fishing areas. This conflict may be rendered mute if the projected fishing benefits due to "artificial upwelling" come to fruition. Another area in which OTEC facility siting would be an incompatible use would arise in national security zones or military exercise areas. There may also be minimal conflicts arising between OTEC and recreational boating, mineral exploitation, ocean sanctuaries and waste disposal.

The 96th Congress of the United States has taken action to resolve many of the potential conflicts surrounding future OTEC plant operation by the passage of Public Law 96-320, The OTEC Act of 1980. The purpose of this extensive, twenty-eight page document is, "To regulate commerce, promote energy self sufficiency, and protect the environment, by establishing procedures for the location, construction, and operation of ocean thermal energy conversion facilities and plantships to produce electricity and energy-intensive products off the coasts of the United States, to amend the Merchant Marine Act, 1936, to make available certain financial assistance for construction and operation of such facilities and plantships; and for other purposes."

The resolution of future conflicts between OTEC facilities and other ocean space use is particularly difficult to predict. However, if OTEC technology moves past the research and developmental stages, a system for leasing the available space, similar to that which exists for the oil industry, is likely to evolve. In viewing future and emerging ocean uses it must naturally be taken into consideration what effect or limitation that use will have on existing activities.

VII. Comparative Cost Calculations of Energy Types

In the 1980's, the Rand Corporation completed extensive modeling studies for the Department of Energy to determine the cost effectiveness of ocean thermal energy conversion systems. The researchers used a design for a 400 MWe OTEC plant located in the Gulf of Mexico, 150 nautical miles west of Tampa, Florida and based their results on the following assumptions : a five year construction period, 6% rate of inflation, 30 year operational life and a 10% cost for capital [93]. The research examined the comparative costs of electrical production between an OTEC plant, nuclear, coal and oil fired power plants. The cost estimates developed are as follows [94] :

Comparative Cost Estimates

OTEC Plant	*96 mills/KwH (-28% to +31% error)
Oil Fired	**68 mills/KwH
Coal Fired	55 mills/KwH
Nuclear Powered	#35 mills/KwH

* mills/KwH = .1 cent per kilowatt hour

** based on oil at \$15.00/bbl.

does not include cost of disposal of waste

There are many sources of cost estimates, the majority of which take an almost unrealistically optimistic view of the potential for OTEC systems to cheaply produce electricity. The most optimistic of these low end estimates is 29.3 mills/KwH, indicating that OTEC power is presently more than three times more cost effective than oil fired power plants and are now an economically profitable method of electric power production [95]. However, of all the cost estimate studies examined, the Rand Corporation's effort appears to be based on the most accurate information and is the most pragmatic.

It is recognized that there are many variables complicating the development of cost estimates for a commercially unproven venture such as an OTEC facility. It is that aspect of the unknown which causes the wide range of possible error present in the cost projections for the production of electrical power through ocean thermal energy conversion systems.

VIII. Secondary Benefits of OTEC Facilities

In addition to the primary benefit of electrical power production of OTEC facilities, there are a variety of secondary applications which are very attractive. The majority of these side benefits would be particularly useful in tropical areas. The specific location of the plant will determine which of the side benefits would be most useful.

One of the most promising side benefits of OTEC plants, as mentioned previously, is the production of freshwater. The procurement of freshwater in tropical island areas is frequently accomplished by collection of rainwater from rooftops and desalination plants and pools. The attraction of freshwater production as a mere side benefit of electrical power production becomes obvious.

Another potentially important side benefit is achieved through the second application of the cold water pumped from the depths. For OTEC plants which are onshore or near shore, the potential for mariculture production could add considerably to the total profitability of the plant. Once the cold nutrient-rich deep ocean water condenses the working fluid, it can then be pumped to ponds on shore to facilitate the growing of shellfish. The affect of "artificial upwelling" is put to use by shellfish which are 30% efficient in converting the extremely high level of

protein production by algae [96]. The technical feasibility of "artificial upwelling" mariculture has already been successfully demonstrated since 1972 in a small plant on St. Croix in the Caribbean [97].

A third side benefit of an OTEC facility where the technical feasibility has been proven, is use in conjunction with open ocean mineral exploitation. The prospect of reclaiming valuable minerals from the ocean floor in the form of manganese nodules has been discussed for many years, but has not yet been accomplished on a commercial basis. One of the many drawbacks preventing the commercially profitable exploitation has been the lack of on-site electrical power and the high transportation costs of the bulk material [98]. An OTEC facility could solve both of those problems by providing on-site electrical power to assist in the collection, processing and refining of the raw material. Specifically, manganese nodules contain only 3% usable minerals by weight which makes the transportation costs of the total nodule impractical [99]. By using the OTEC platform and available electricity to preprocess the nodules or minerals on site, a more refined product of lower weight can be transported at a lower cost. Additionally, many of the mineral processing and refining steps require freshwater which is becoming a more scarce land resource, but can be readily produce as a by-product of the OTEC facility.

A somewhat unusual side benefit of OTEC which has been considered, is making use of the discharged cold water, after it has picked up heat while condensing the working fluid, to melt icebergs [100]. The iceberg melt would then be utilized for irrigation of arid areas to produce agricultural crops. The iceberg would be towed to the OTEC plant which would, by virtue of the operating requirements, be located in an area of the world which could benefit from the availability of irrigation water. Further, once the plant water is used to melt the iceberg, its temperature would be reduced and could then be recycled through the system, increasing the operating efficiency of the plant due to an increased temperature differential [101]. A variety of other interrelated uses between the OTEC plant and the iceberg melt have also been evaluated, adding to the possibilities of the undertaking.

A variety of other secondary OTEC uses have been tested or at least hypothesized. The electrical power produced could be converted to stored energy in fuel cells and transported to the desired area of use [102]. As discussed previously, the facility could be used to produce ammonia for use in the plant as the working fluid or for sale as agricultural fertilizer [103]. Additionally, the discharged cold water from OTEC-1 has been successfully used for the production of specialty crops in tropical areas such as

strawberries which require cool temperatures to develop fruit [104].

OTEC systems are a new technology, but as is indicated by the above list of proven or potential side benefits it has many secondary uses which add to the overall attractiveness of the concept. If OTEC plants become more common in the future the list of alternate secondary benefits will only grow.

IX. Conclusion

With current fossil fuel supplies dwindling, our nation needs to reemphasize the search for alternate forms of energy production. One possible solution may be found in the ocean. It has an almost unlimited supply of untapped solar energy. OTEC could be the process that could turn this untapped resource into usable energy.

In the 1970's, the oil embargo imposed by the OPEC Cartel resulted in an oil shortage in the U.S. and an increased awareness of our dependence on foreign oil. The U.S. undertook an aggressive research program to find alternate forms of energy and in the late 1970's, when OTEC research intensity was at its height, many sources were predicting commercial plants would be in operation by the mid-1980's. However, as everyone is aware, the instability of the Middle East caused a collapse of the OPEC Cartel,

leading to subsequent reductions in the cost of imported oil. Following the reduction in the cost of oil, much of the interest in alternate sources of energy was abandoned and the U.S. has since forgotten the gas lines and once again become complacent and increasingly dependent on foreign oil.

It is easy to pontificate regarding reduction of America's dependence on foreign oil, but the economics of alternate sources of energy remains a critical component of the discussion. Utilizing the formula developed by the Rand Corporation and inserting the current price of oil (\$21.00 /bbl), indicates that OTEC is not at present an economically profitable venture strictly for electrical production when compared to nuclear, oil or coal powered generation plants. However, again based on the Rand formula, OTEC was economically competitive when oil prices reached \$25.00 per barrel in the 1970's and actually cheaper at oil costs above that amount. At \$25.00 per barrel it costs approximately 100 mills/KwH for oil based electrical production, while OTEC production costs only 96 mills/KwH [105]. Therefore, if oil prices rise above \$25.00 per barrel we could economically shift to OTEC produced electrical power. However, that option will not be available with the current lackadaisical pursuit of needed technology.

A review of the literature indicates that additional research and development is required in various physical

components of an OTEC facility. This is particularly true of the construction material, design and deployment method of the cold water suction pipe [106]. There is also additional work required on the materials and design involved in the electrical cable to carry the power to the use site. The Hawaii deep water cable (HDWC) program is aggressively researching many of the problems and is making progress to achieve solutions [107]. Finally, biofouling will continue to cause degraded operation of the systems. The new thermoplastic coatings used by the U.S. Navy hold much promise and with additional refinement will no doubt be preferred over both the toxic soluble paints and biocide (chlorine) injections.

A renewed, aggressive interest in OTEC research is required to solve the technological problems to ensure preparedness for potential oil shortages of the future and to generally reduce America's dependence on foreign oil. The future will eventually see OTEC plants in use and steps should be taken now to prevent the wasted effort involved in a hurried approach to development. OTEC technology should be developed to an economically operational status now, before oil prices once again rise to the point at which OTEC becomes an economically acceptable alternative.

It is recognized that there is a tremendously steep learning curve involved in any new technology so as

operational time and knowledge increases, costs are reduced rapidly. The cost estimates developed by Rand Corporation are for the first commercial plant, whereas follow-on plants would be built and operated more cheaply and therefore more competitively. Additionally, the multitude of secondary benefits could all lead to increased profits once the plant is operational.

In conjunction with the need to reduce America's dependence on foreign oil, the benefits to society through the reduction of environmental damage could be tremendous. Currently, fossil fueled plants, and nuclear power plants all have a negative impact on the environment. They pollute the air, enhance the greenhouse effect, discharge toxic substances, and produce radioactive waste. The exact effect OTEC will have on the marine environment is not completely known, but it is certainly the more environmentally attractive method of electrical production.

In spite of OTEC's early touting as the perfect energy alternative, supplying all of America's energy needs, it must be realized that, even when fully utilized, OTEC will be merely a supplemental source of energy. It will be particularly attractive to island states and the Southeastern United States, but will mainly assist in reducing the total national energy requirement. It will do this by supplementing energy demands in local areas, providing power

for energy-intensive products and meeting the electrical needs of the island areas which are dependent on the United States.

OTEC should be given intelligent support now, in the form of increased tax incentives and construction subsidies to ensure the technology is available for the near future. The U.S. must reduce its foreign dependence before oil prices again rise to unacceptable levels and also take affirmative action to set the example to reduce the degradation of the global environment. OTEC facilities must be developed now to progress toward both of these goals.

Figure 1.
58

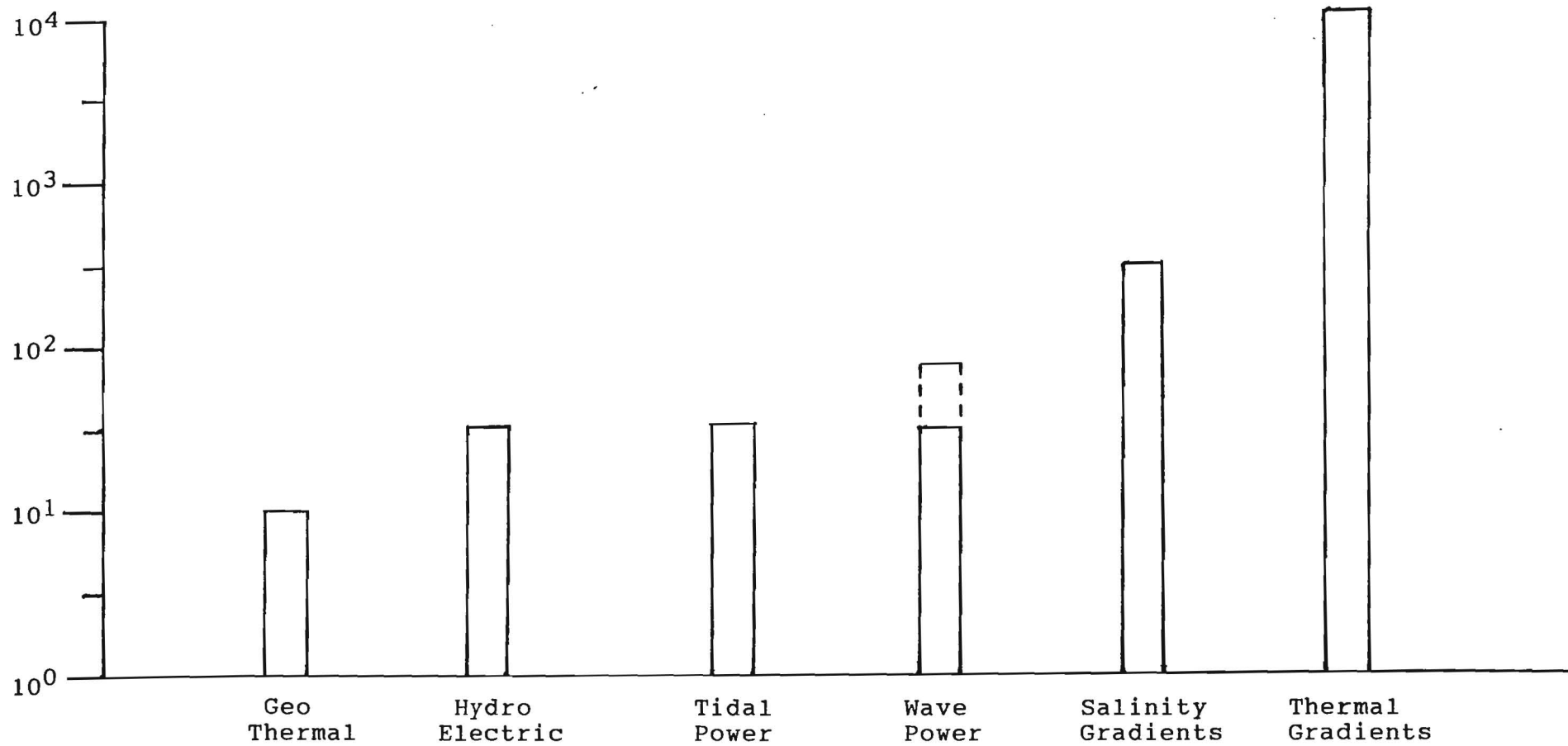

Figure 1. Relative Potentials of Ocean Energy Sources [108]

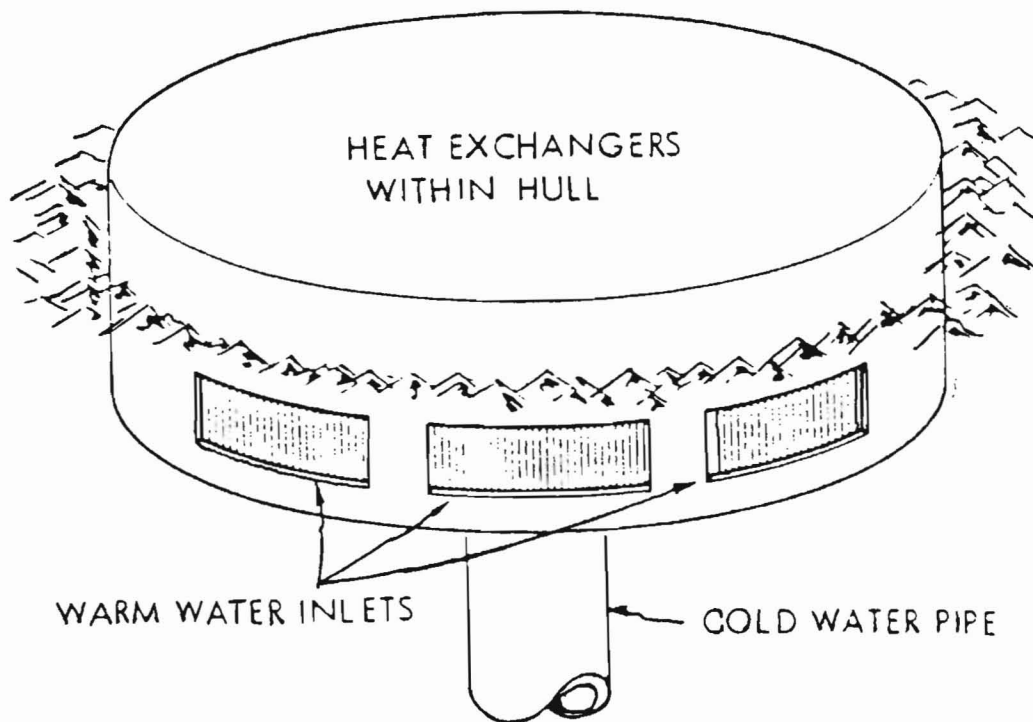

Figure 2. Barge Type OTEC Platform [109]

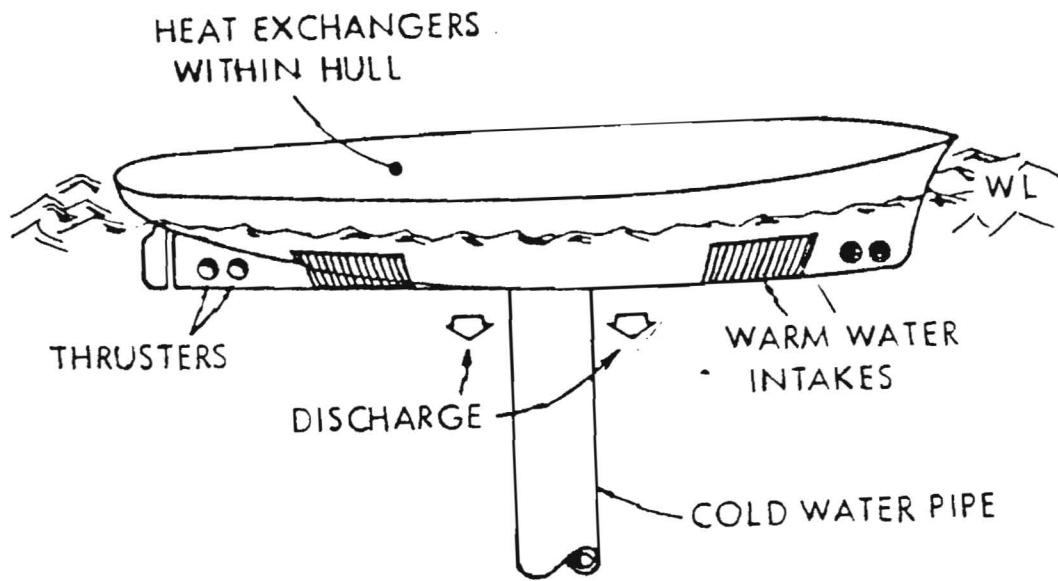

Figure 3. Ship Type OTEC Platform [110]

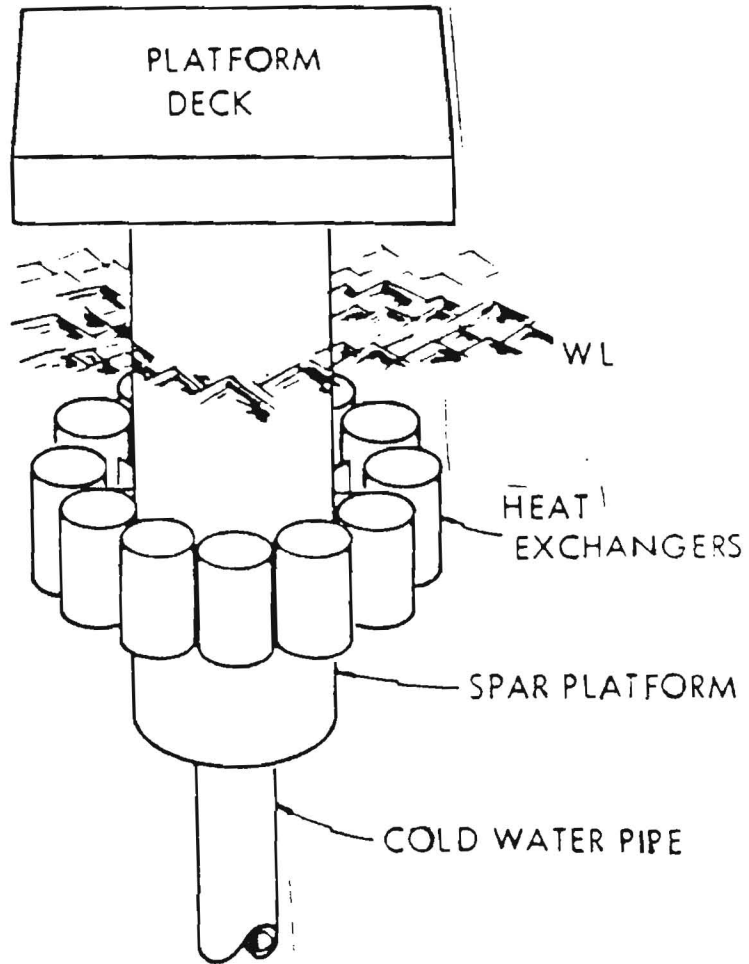

Figure 4. Spar Type OTEC Platform [111]

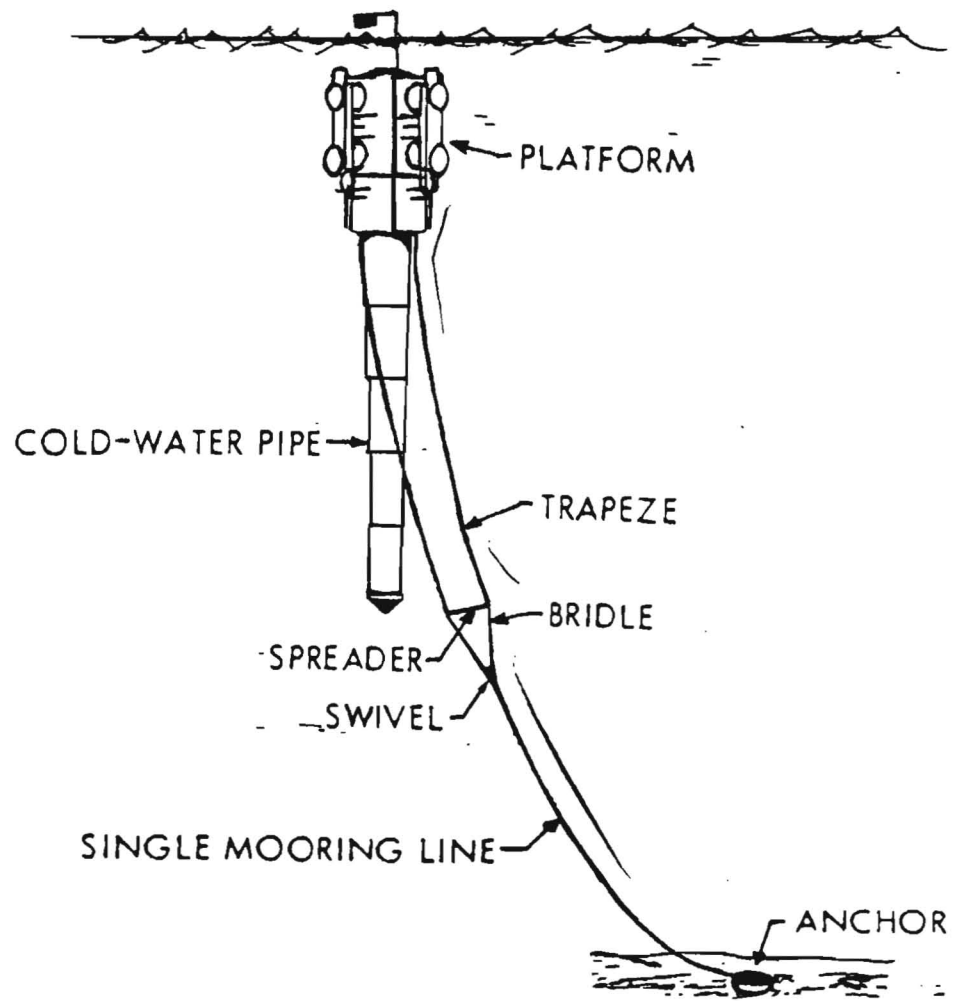

Figure 5. Semi-Submersible OTEC Platform [112]

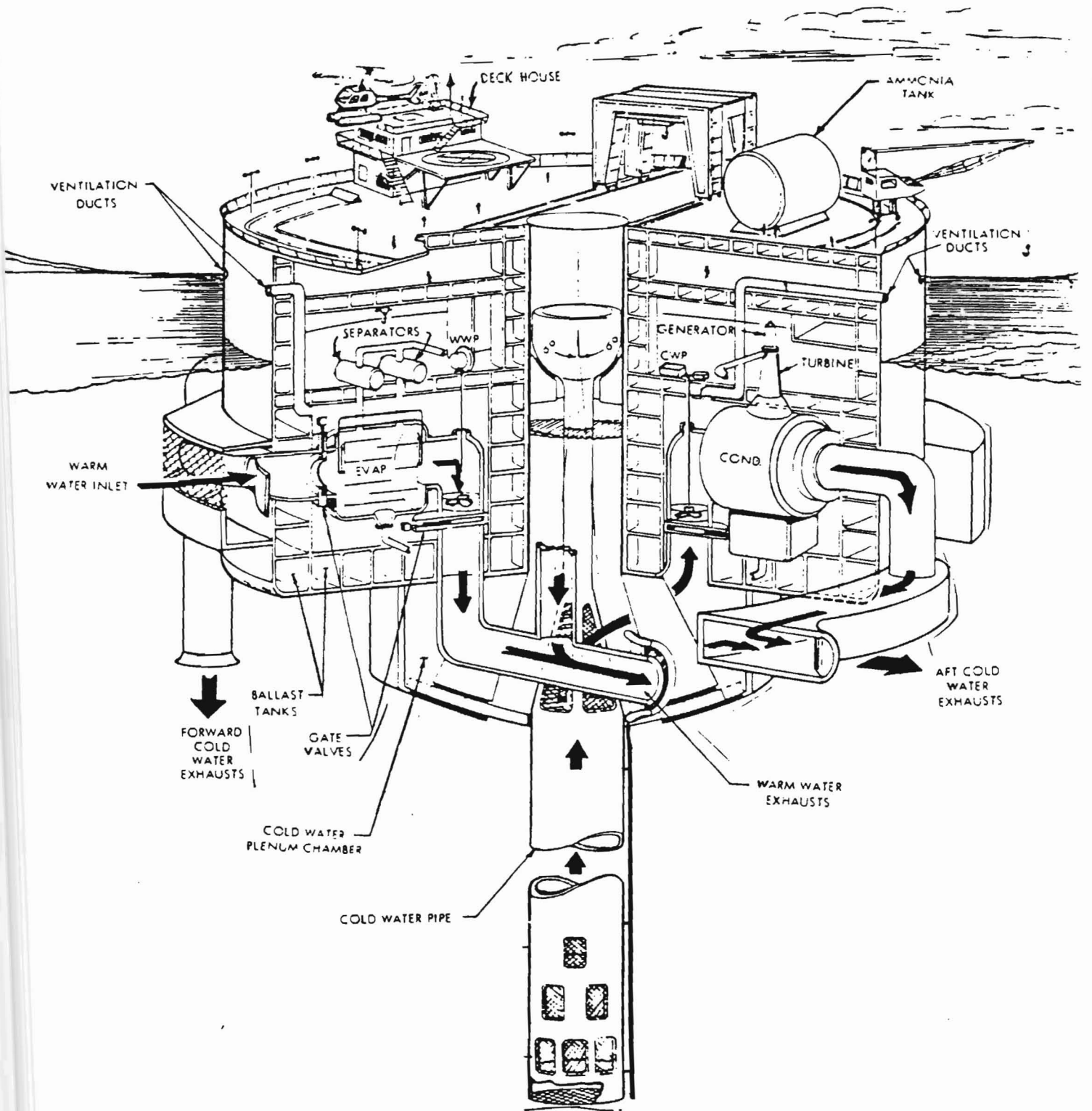

Figure 6. Artist's Conception of OTEC Facility [113]

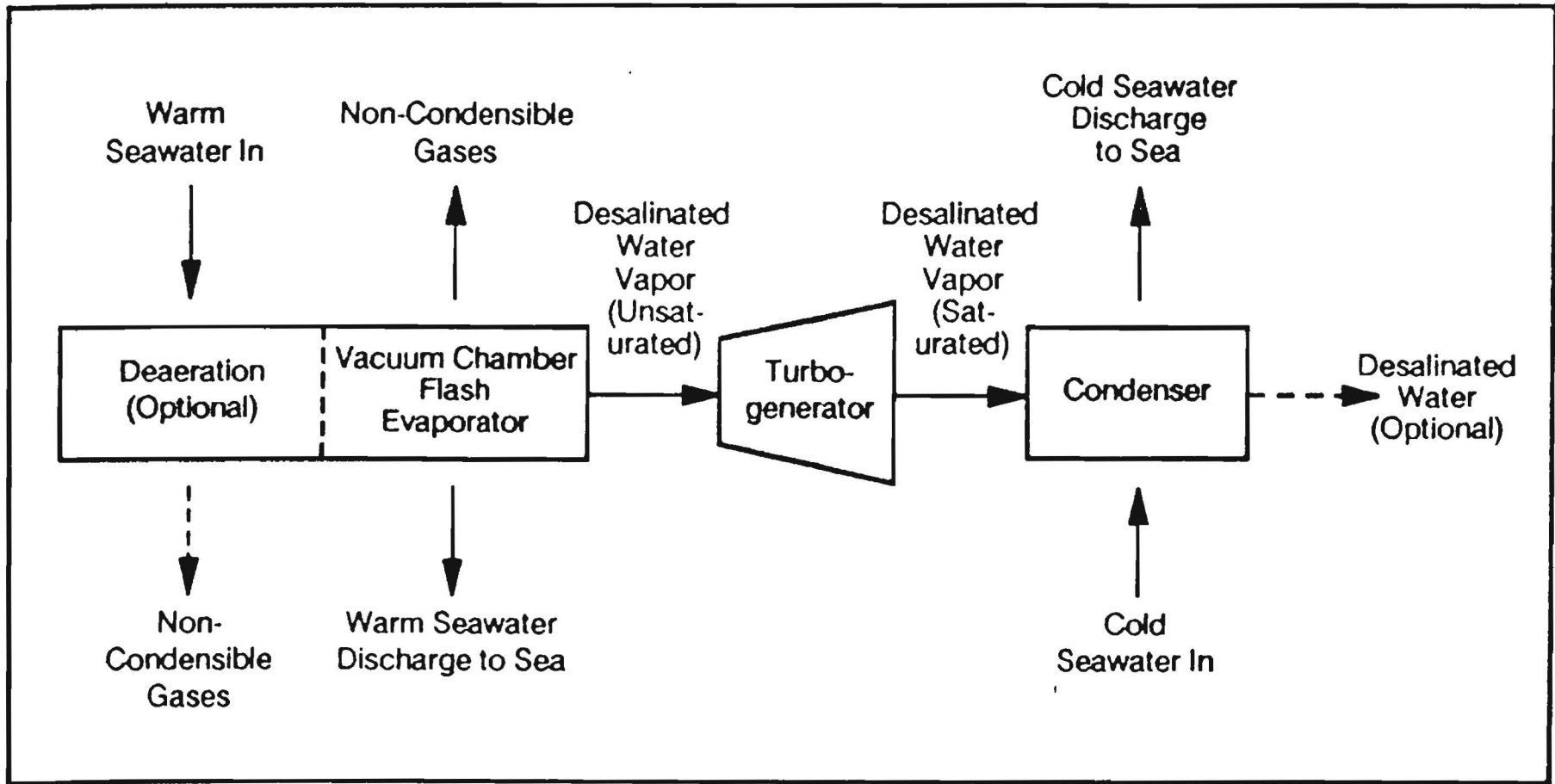

Figure 7. Schematic of Open Cycle OTEC System [114]

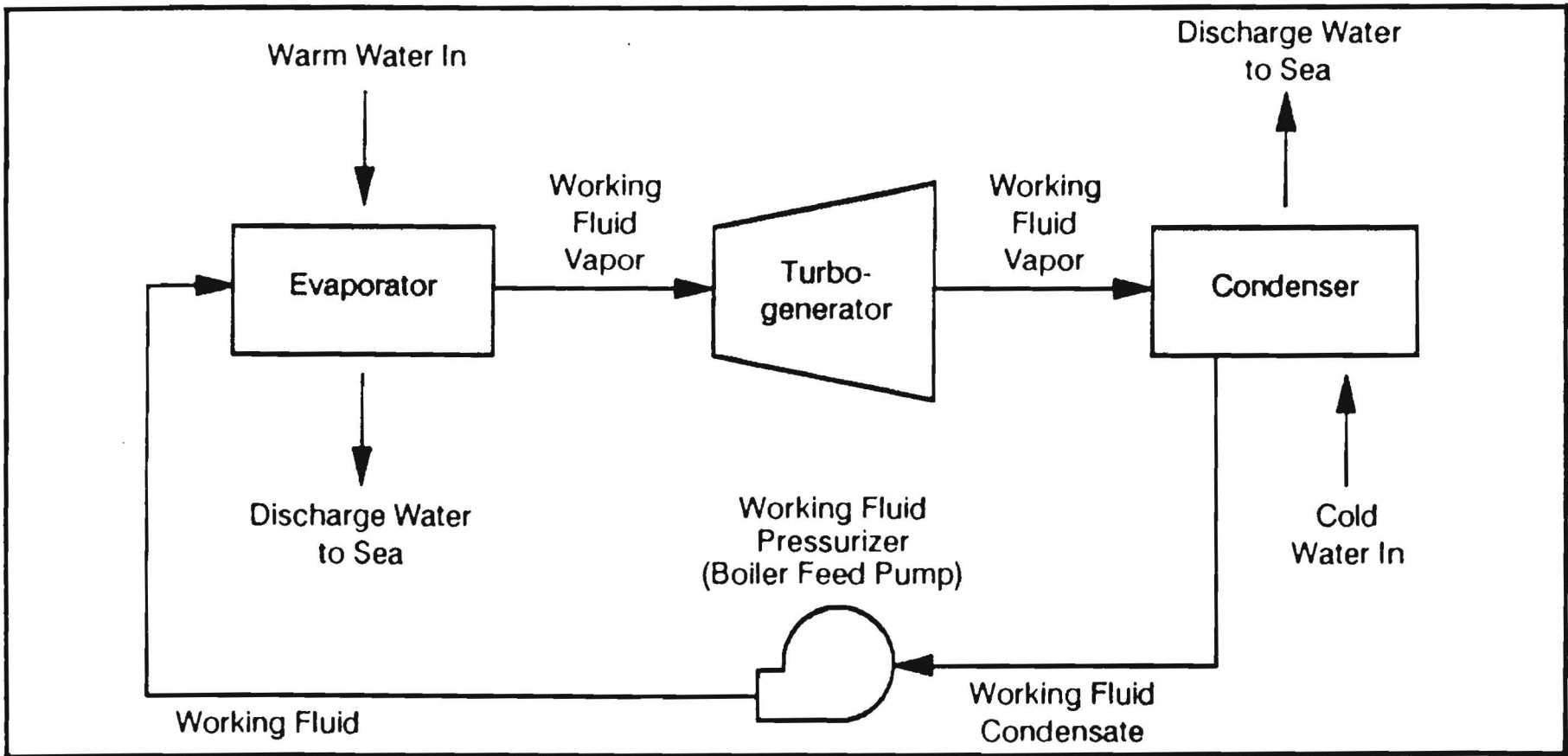

Figure 8. Schematic of Closed Cycle OTEC System [115]

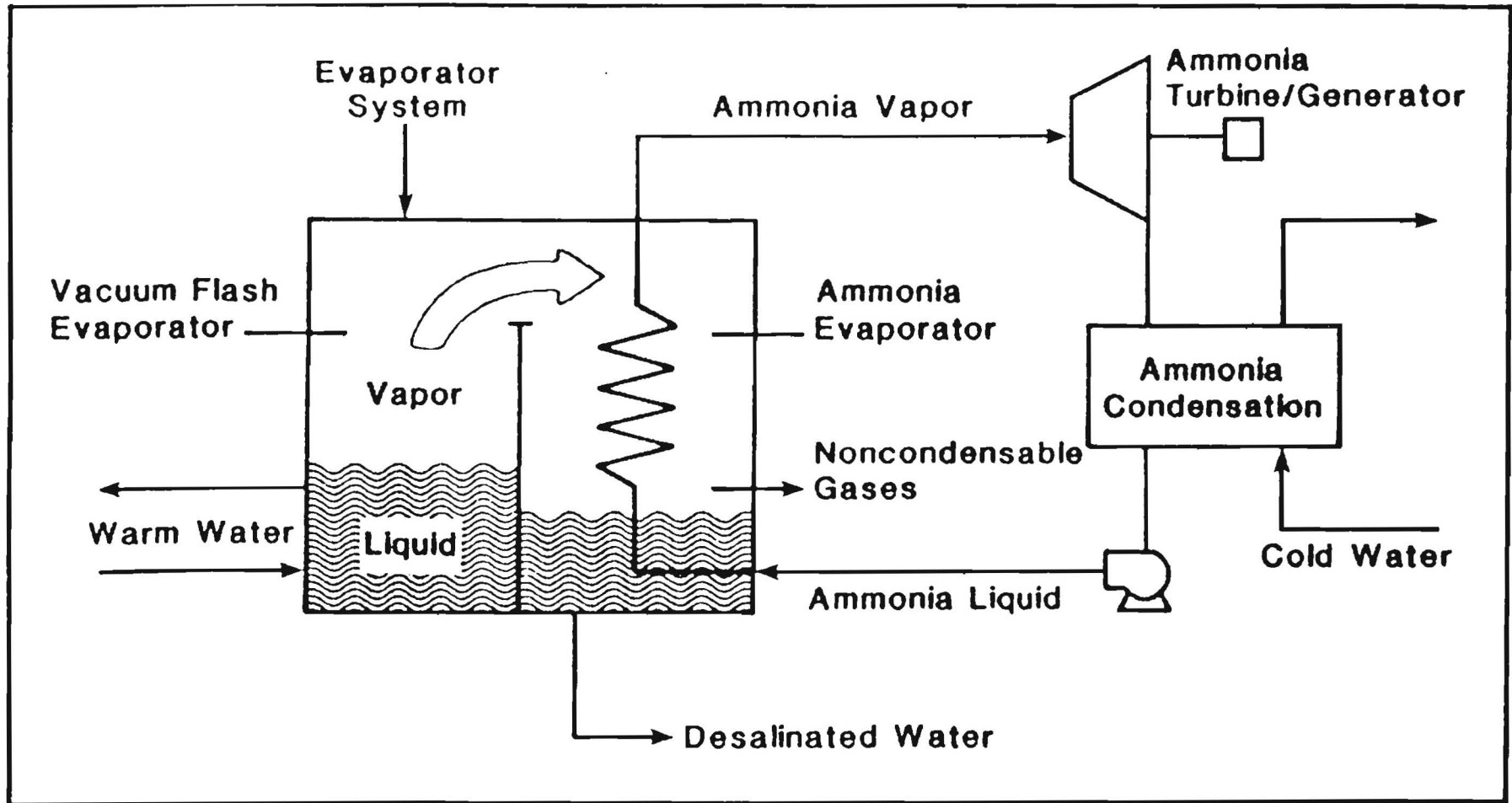

Figure 9. Schematic of Hybrid Cycle OTEC System [116]

WORLD OTEC THERMAL RESOURCE ΔT ($^{\circ}\text{C}$) BETWEEN SURFACE AND 1000 METER DEPTH

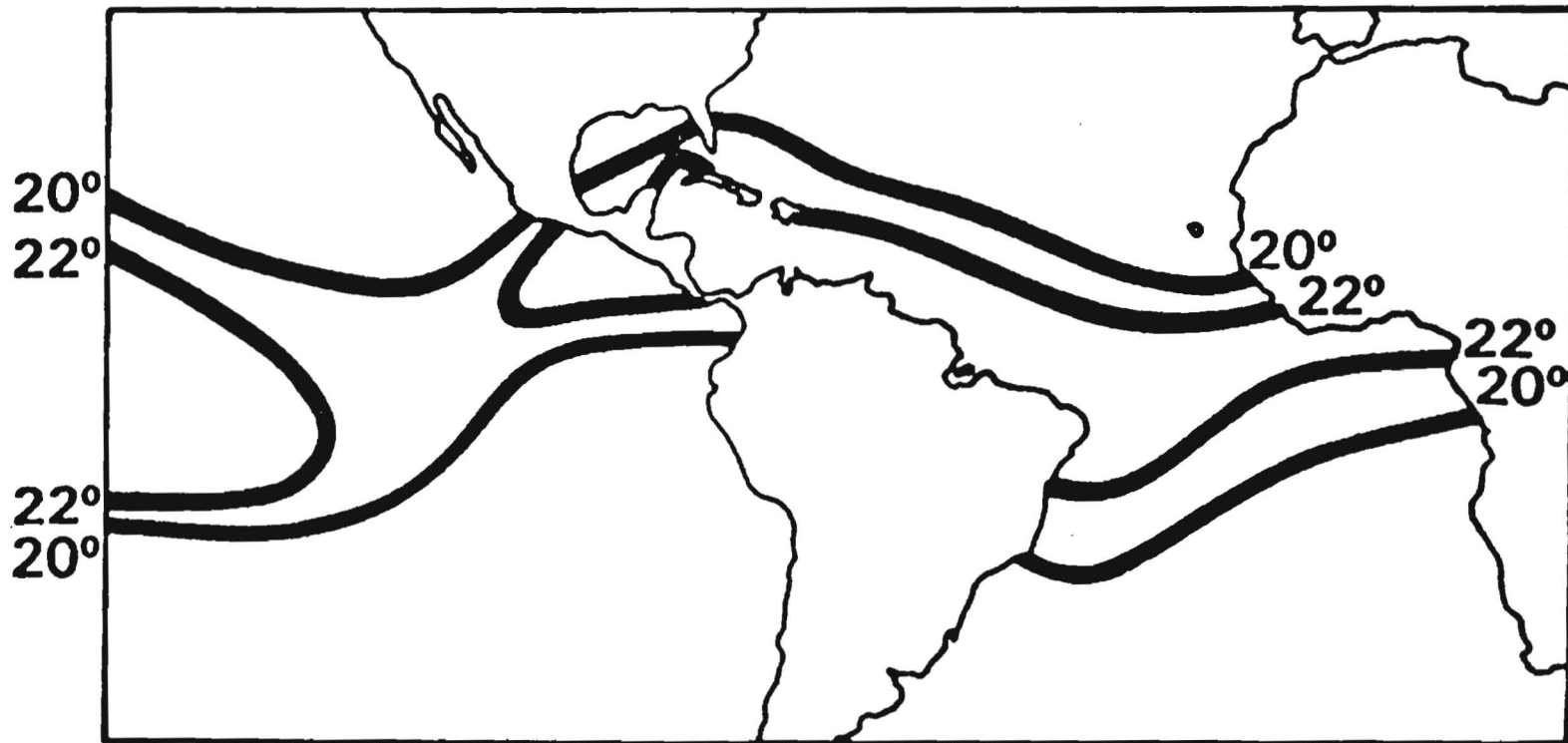

Figure 10. Global OTEC Thermal Resource [117]

Figure 10.
67

SYNTHESIS OF CONSTRAINTS ON RESOURCE AVAILABILITY

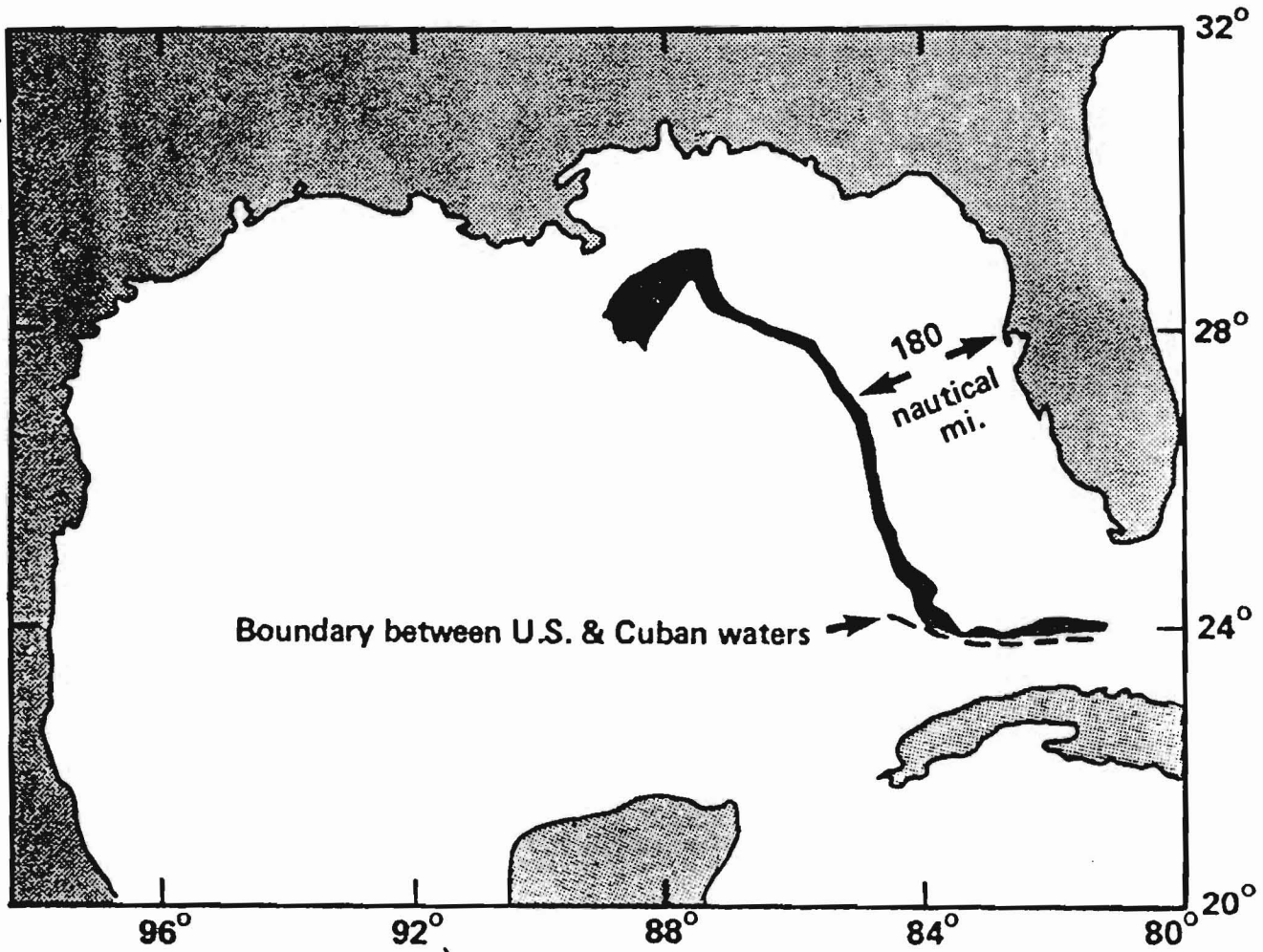

Figure 11. Gulf of Mexico OTEC Resource Extent [118]

Figure 12. Ocean Use List

<u>Ocean Use</u>	<u>Category of Use</u>
1. Navigation	Nonconsumptive
- Transportation	
- Recreation	
- Military	
2. Recreation	Nonconsumptive
3. Fishing	Consumptive (Renewable)
- Commercial	
- Sport	
4. Petroleum Extraction	Consumptive (Nonrenewable)
5. Mineral Exploitation	Consumptive (Nonrenewable)
- Precious Metals	
- Construction Materials	
- Industrial Metals	
6. Military Uses	Nonconsumptive
- National Security	
7. Waste Disposal	Consumptive (if Damaging)
8. Research	Nonconsumptive
9. Sanctuary Areas	Nonconsumptive

REFERENCES

- 1.) Claude, Georges, 1930, "Power From the Tropical Sea" : Mechanical Engineering, 52 (12), 1039.
- 2.) Freon is a patented trademark name of the Dupont Chemical Company to describe a variety of nonflammable gaseous or liquid flouorocarbons used as refrigerants or aerosol propellants.
- 3.) Claude, Georges, p. 1039.
- 4.) Penney, T.R. and Bharatan, D., 1987, "Power From the Sea" : Scientific American, Jan., pp. 86-87
- 5.) Ibid., p. 87.
- 6.) Richards, Adrian F., 1976, "Extracting Energy From the Oceans; A Review" : Wave and Salinity Gradient Energy Conversion Workshop Proceedings, Report No. COD-2996-1, pp. 5-8.
- 7.) Ibid., p. 6.
- 8.) Penney, T.R. and Bharathan, D., p. 89.
- 9.) Ibid., p. 89.
- 10.) Department of Energy, 1986, "Federal Ocean Energy Technology" : Program Summary for Fiscal Year 1986, Report No. DE-AC01-86CE30844, pp. 3, 5, 17.
- 11.) Penney, T.R. and Bharathan, D., p.89.
- 12.) Tabata, R.S., 1981, "Solar Energy From the Sea" : UNIHISEAGRANT, Report No. AB-82-01, pp. 1-3.
- 13.) Penney, T.R. and Bharathan, D., p. 89.
- 14.) Pei, R.Y., 1980, Rand Note No. N-1517-DOE, p. 5.
- 15.) Ibid., p. 6.
- 16.) Penney, T.R. and Bhrathan, D., p. 91.
- 17.) Wright, D.E., Wagner, W. and Shoji, J., 1979, "Variflux and Finned-Plate OTEC Heat Exchanger Technology Status" : Proceedings of Sixth OTEC Conference, Wash., D.C., Vol.II, p. 5D-6/2.

- 18.) Basse, J.L. and Park, Y.H., 1989, "Corrosion in Slowly Flowing Ocean Thermal Conversion Seawater" : Materials Performance, Feb., pp. 45-47.
- 19.) Penney, T.R. and Bharathan, D., p. 89.
- 20.) Lott, D.F. and Tuovilla, S.M., 1979, "Fouling Countermeasures Status of Two Mechanical Cleaning Systems and Chlorination" : Proceedings of Sixth OTEC Conference, Wash., D.C., Vol. II, p. 8A-4/1.
- 21.) Ibid., p. 8A-4/3.
- 22.) Vincent, S.P. and Kostors, C.H., 1979, "Performance Optimization of an OTEC Turbine" : Proceedings of Sixth OTEC Conference, Wash., D.C., Vol. I, p. 4A-3/2.
- 23.) Penney, T.R. and Bharathan, D., p. 91.
- 24.) Vincent, S.P. and Kostors, C.H., p. 4A-3/2.
- 25.) McGuinness, T., Griffin, A. and Hove, D., 1979, "Preliminary Designs of OTEC Cold Water Pipes" : Proceedings of Sixth OTEC Conference, Wash., D.C., Vol. I, p. 5B-1/1.
- 26.) Georges, CLaude, p. 1041.
- 27.) McGuinness, T., Griffin, A. and Hove, D., p. 5D-1/3.
- 28.) Department of Energy, 1986, p. 20.
- 29.) Ibid., p. 21.
- 30.) Claude, Georges, p. 1044.
- 31.) Dugger, D.L., et al., 1975, "Tropical Ocean Thermal Power Plant Producing Ammonia and Other Products" : Proceedings, Third Workshop on Ocean Energy Conversion (OTEC), pp. 106-113.
- 32.) Trimble, L.C., Meesinger, B.L. and Ulbrich, H.G., "Ocean Thermal Energy Conversion System Study Report " : Proceedings, Third Workshop on Ocean Thermal Energy Conversion OTEC, pp. 162-169.
- 33.) Dugger, D.L., et al., p. 109.
- 34.) Barr, R.A., 1975, "Evaluation of Platform Designs for Ocean Thermal Power Plants" : Proceedings, Third Workshop on Ocean Thermal Energy Conversion (OTEC), pp. 162-169.

- 35.) Simensen, A.L. and Farmer, W.E., 1979, "Tuned Sphere Stable OTEC Platform" : Proceedings of Sixth OTEC Conference, Wash., D.C., Vol.I, p. 4B-8/1.
- 36.) Douglass, R.H., 1975, "Panel Discussion of Issues Raised by Systems Study Reports" : Proceedings, Third : Workshop on Ocean Thermal Energy Conversion (OTEC), p. 41.
- 37.) Barr, R.A., 1975, p. 164.
- 38.) Scott, R.J., 1979, "Conceptual Designs and Costs of OTEC 10/40 MW Spar Platforms" : Proceedings of Sixth OTEC Conference, Wash., D.C., Vol. I, p. 4B-1/6.
- 39.) Simensen, A.L. and Farmer, W.E., p. 4B-8/5.
- 40.) Homma, T. and Kamoya, 1977, "Conceptual Design and Economic Evaluation of OTEC Power Plants in Japan" : Proceedings, Fifth Workshop on Ocean Thermal Energy Conversion (OTEC), pp. V91-V96.
- 41.) Ibid., p. V93.
- 42.) Rogers, L.J., et al., 1988, "Converting Ocean Thermal Energy for Commercial Use in the Pacific" : Sea Technology, Oct., pp. 23-24.
- 43.) Solar Energy Research Institute (SERI), 1988, "Open-Cycle OTEC Research at the Seacoast Tests Facility" : Report No. SERI-SP-253-3329, p. 2.
- 44.) Penney, T.R. and Bharathan, D., p. 90.
- 45.) Ibid., p. 91.
- 46.) Douglass, R.H., p. 41.
- 47.) Ibid., p. 42.
- 48.) Dugger, G.L., et al., p. 108.
- 49.) Ibid., p. 110.
- 50.) Gritton, E.C., Pei, R.Y., and Hess, R.W., 1980, "Rand Executive Briefing" : Report No. R-2641-DOE, Aug., p. 7.
- 51.) Ibid., p. 8.
- 52.) Ibid., p. 9.

- 53.) Mathers, J.T., 1985, Open Ocean Anchoring Systems, (Glenview, Illinois : Scott, Foresman and Company), pp. 147-152.
- 54.) For differing estimates of the power potential of the Gulf of Mexico see also : Sutherland, P.L., Arey, F.G. and Guild, D.H., 1979, "Potential for Ocean Thermal Energy Conversion, Electric Power Generation in the Southeast Region" : Proceedings of Sixth OTEC Conference, Wash., D.C., Vol II, p. 5A-1/1. or Schrieber, W.D., 1983, "OTEC Potential in the Gulf of Mexico" : Ocean Technology, Oct., pp. 21-23.
- 55.) Pei, R.Y., 1980, "Resource Estimate for Ocean Thermal Energy Conversion (OTEC) in the Gulf of Mexico" : Rand Note No. N-1517-DOE, p.6.
- 56.) Ibid., p. 7.
- 57.) Molinari, R.L., 1979, "Thermal and Current Data from the Gulf of Mexico and South Atlantic Relative to Placement of OTEC Plants" : Proceedings of Sixth OTEC Conference, Wash., D.C., Vol. I, p. 5C-5/1.
- 58.) Vokovich, F.M., 1979, "Large Tongues of Cold Water in the Eastern Gulf of Mexico and their Potential Effect to OTEC" : Proceedings of Sixth OTEC Conference, Wash., D.C., Vol. I, p. 2C-3/1.
- 59.) Ibid., p. 2C-3/2.
- 60.) Pei, R.Y., p. 14.
- 61.) Ibid., p. 15.
- 62.) Ibid., p. 16.
- 63.) Ibid., p. 3.
- 64.) Solar Energy Research Institute (SERI), 1986, "Environmental Impacts of Ocean Thermal Energy Conversion" : Report No. SERI-SP-271-2796, pp. 17-19.
- 65.) Sullivan, S.M., Sands, M.D., Donat, J.R., et al., 1981, "Draft; Environmental Assessment Ocean Thermal Energy Conversion (OTEC) Pilot Plants" : Lawrence Berkley Laboratory, Earth Sciences Division, p. 1-17.
- 66.) Ibid., p. 18.

- 67.) Eurocean Marine Study Group, 1977, " A European Industrial Evaluation of the Ocean Thermal Conversion System" : Monaco Association European Oceanique, p. 104.
- 68.) Sullivan, S.M., et al., p. 24.
- 69.) Hileman, Bette, 1984, "Recent Reports on the Greenhouse Effect" : Environmental Science Technology, Vol. 18, No. 2, p. 45A.
- 70.) Ibid., p. 46A.
- 71.) Sullivan, S.M., et al., p. 24.
- 72.) Wilde, P., 1980, "Environmental Monitoring and Assessment Program at Potential OTEC Sites" : Proceedings of Seventh OTEC Conference, Wash., D.C., Vol. II, p. 6A-4/1.
- 73.) Lewis, L.F., 1979, "OTEC Environmental and Resource Assessment Program" : Proceedings of Sixth OTEC Conference, Wash., D.C., Vol. I, p. 6A-1/1.
- 74.) Quinby-Hunt, M.S., 1979, "Comparison of Nutrient Data from Four Potential OTEC Sites" : Proceedings of Sixth OTEC Conference, Wash., D.C., Vol. II, p. 7D-2/1.
- 75.) Roels, O.A., Laurence, S. and Hemelryck, L.V., 1979, "The Utilization of Cold, Nutrient-Rich Deep Ocean Water for Energy and Mariculture" : Ocean Management, No. 5, pp. 199-210.
- 76.) Ibid., p. 200.
- 77.) Ibid., p. 201.
- 78.) Bathen, Karl H., 1975, "Oceanographic and Socio-Economic Aspects of an Ocean Energy Conversion Pilot Plant in Subtropical Hawaiian Waters" : Proceedings, Third Workshop on Ocean Thermal Energy Conversion (OTEC), pp.162-169.
- 79.) Ibid., p. 168.
- 80.) Bureau of Naval Personnel, 1970, Principles of Naval Engineering, NAVPERS 10788-B, Catalog No. D208.112/:EN3/2/970.
- 81.) Solar Energy Research Institute (SERI), 1986, p. 19.
- 82.) Ibid., p. 17.

- 83.) Ibid., p. 21.
- 84.) McGuinness, T., et al., p. 5B-1/3.
- 85.) Lott, D.F. and Tuovilla, S.M., p. 8A-4/1.
- 86.) Ibid., p. 8A-4/2.
- 87.) Miller, R.T., Gertz, J.J. and Cunninghis, S., 1979, "Preliminary Designs of 10 MWe and 50 MWe Power Modules" : Proceedings of Sixth OTEC Conference, Wash., D.C., Vol. I, p. 4A-1/2.
- 88.) Sullivan, S.M., et al., p. 21.
- 89.) Basse, J.L. and Park, Y.H., 1989, "Corrosion in Slowly Flowing Ocean Thermal Energy Conversion Seawater" : Materials Performance, Feb., pp. 46-51.
- 90.) Ibid., p.48.
- 91.) Othmer, D.F. and Roels, O.A., 1978, "Power, Fresh Water, and Food from Cold Deep Sea Water" : Science, Oct., p. 182.
- 92.) Knight, G.H., Nyhart, J.D. and Stein, R.E., 1977, Ocean Thermal Energy Conversion, (Lexington, MA : D.C. Heath and Company), pp. 91-108.
- 93.) Gritton, E.C., et al., pp. 2-4.
- 94.) Ibid., pp. 33-35.
- 95.) Jacobsen, W.E. and Manley, R.N., 1979, "Analysis of Prospects for OTEC Commercialization for Baseload Power" : Proceedings of Sixth OTEC Conference, Wash., D.C., Vol. I, p. 3B-5/1-5/7.
- 96.) Roels, D.A., et al., p. 199.
- 97.) Ibid., p. 202.
- 98.) Harlow, E.H., 1979, "OTEC Power for Ocean Minerals" : Proceedings of Sixth OTEC Conference, Wash., D.C., Vol. I, P. 3B-6/1.
- 99.) Ibid., p. 3B-6/2.

- 100.) Randall, J.M., Camirand, W.M. and Hautala, E., 1982, "Waste Heat from OTEC Condenser to Melt Icebergs for Irrigation Water" : Marine Technology Society Journal, 22:64-8, Oct., p.65.
- 101.) Ibid., p. 67.
- 102.) Krueger, R.B., 1980, "The Promise of OTEC" : Marine Technology Society Journal, Vol. 14, No. 2, p. 32.
- 103.) Dugger, G.L., et al., p. 107.
- 104.) MacDonald, C.D. and Deese, H.E., 1988, "Hawaii's Ocean Industries; Relative Economic Status" : Proceedings of the Pacific Congress on Marine Science and Technology, Honolulu, Hawaii, p. 9.
- 105.) Gritton, E.C., et al., p. 29.
- 106.) McGuinness, T., Griffin, A. and Hove, D., p. 5B-1/1.
- 107.) Dexter, S.C. and Culbertson, C.D., 1985, "Deep Water Cable Corrosion" : Materials Performance, Vol. 29, No. 19, p. 16.
- 108.) Richards, Adrian F., p. 6.
- 109.) Douglass, R.H., p. 42.
- 110.) Ibid., p. 43.
- 111.) Ibid., p. 44.
- 112.) Ibid., p. 44.
- 113.) Source unknown. Drawing found on file at the Coast Guard Academy Library, Groton, CT. seperated from original work.
- 114.) Solar Energy Research Institute (SERI), 1988, "Ocean Energy Program Summary" : Report No. DOE/CH10093-43, p. 3.
- 115.) Ibid., p. 2.
- 116.) Ibid., p. 4.
- 117.) Gritton, E.C., Pei, R.Y., and Hess, R.W., p. 7.
- 118.) Ibid., p. 9.