

2021

An inexpensive, 3D-printable breast muscle meter for field ornithologists

Luke L. Powell

Adam Metallo

Crinan Jarrett

Nathan W. Cooper

Peter P. Marra

See next page for additional authors

Follow this and additional works at: https://digitalcommons.uri.edu/nrs_facpubs

Citation/Publisher Attribution

Powell, L.L., Metallo, A., Jarrett, C., Cooper, N.W., Marra, P.P., McWilliams, S.R., Bauchinger, U. and Dossman, B.C. (2021), An inexpensive, 3D-printable breast muscle meter for field ornithologists. *J. Field Ornithol.*, 92: 67-76. <https://doi.org/10.1111/jof.12355>
Available at: <https://doi.org/10.1111/jof.12355>

This Article is brought to you for free and open access by the Natural Resources Science at DigitalCommons@URI. It has been accepted for inclusion in Natural Resources Science Faculty Publications by an authorized administrator of DigitalCommons@URI. For more information, please contact digitalcommons@etal.uri.edu.

Authors

Luke L. Powell, Adam Metallo, Crinan Jarrett, Nathan W. Cooper, Peter P. Marra, Scott R. McWilliams, Ulf Bauchinger, and Bryant C. Dossman

An inexpensive, 3D-printable breast muscle meter for field ornithologists

Luke L. Powell,^{1,2,3,4,11} Adam Metallo,⁵ Crinan Jarrett,^{2,3} Nathan W. Cooper,¹
Peter P. Marra,^{1,6} Scott R. McWilliams,⁷ Ulf Bauchinger,^{8,9} and
Bryant C. Dossman¹⁰

¹Migratory Bird Center, Smithsonian Conservation Biology Institute, National Zoological Park, Washington, D.C 20013-7012, USA

²Institute of Biodiversity, Animal Health and Comparative Medicine, University of Glasgow, Glasgow G128QQ, Scotland

³Biodiversity Initiative, Houghton, Michigan 49931, USA

⁴Department of Biosciences, Durham University, Durham DH13LE, UK

⁵Office of the Chief Information Officer, Smithsonian Institution, Washington, D.C 20906, USA

⁶Department of Biology and McCourt School of Public Policy, Georgetown University, Washington, D.C 20057, USA

⁷Department of Natural Resources Science, University of Rhode Island, Kingston, Rhode Island 02881, USA

⁸Institute of Environmental Sciences, Jagiellonian University, Kraków 30-387, Poland

⁹Nencki Institute of Experimental Biology, Polish Academy of Sciences, Warsaw 02-093, Poland

¹⁰Department of Natural Resources, Cornell University, Ithaca, New York 14850, USA

Received 1 October 2020; accepted 11 January 2021

ABSTRACT. The size of the pectoral muscle is an important component of body condition in birds and has been linked to indices of fitness and migratory performance. Bauchinger et al. (2011. *Journal of Ornithology* 152: 507–514) developed, calibrated, and validated an aluminum “muscle meter” device that estimates the size of pectoral muscles noninvasively. To make this tool more widely available, we created a CAD model from 3D-scan data of the aluminum muscle meter that can be 3D-printed in durable plastic for ~ \$30 USD. We tested this device on seven species of songbirds in Jamaica, The Bahamas, Cameroon, Equatorial Guinea, and Michigan. We demonstrate that the breast muscle meter measurements are (1) repeatable among users, (2) correlated with a four-category visual breast muscle scoring system, and (3) correlated with scaled mass index (an index of body condition). Muscle scores from our device outperformed the traditional four-category muscle scoring system in predicting scaled mass index. Finally, with our device, we quantified the increasing breast muscle size of American Redstarts (*Setophaga ruticilla*) from March through May as they prepared for spring migration. Given the precision of the 3D-scanning hardware used to generate our 3D image for printing, we produced a plastic muscle meter that is as precise and useful as the aluminum original, but more cost-effective and widely available.

RESUMEN. Un medidor de músculo pectoral económico e imprimible en 3D para ornitólogos de campo

El tamaño del músculo pectoral es un componente importante de la condición corporal en aves y se ha relacionado con índices de aptitud y rendimiento migratorio. Bauchinger et al. (2011. *Journal of Ornithology* 152: 507-514) desarrollaron, calibraron y validaron un “medidor de músculos”, un dispositivo de aluminio que estima el tamaño de los músculos pectorales de forma no invasiva. Para hacer esta herramienta ampliamente disponible, creamos un modelo CAD a partir de datos de escaneo 3D del medido de músculos de aluminio que se puede imprimir en 3D en plástico duradero por ~ \$ 30 USD. Probamos este dispositivo en siete especies de pájaros cantores en Jamaica, Las Bahamas, Camerún, Guinea Ecuatorial y Michigan. Demostramos que las medidas del medidor de músculo del pecho: 1) son repetibles entre usuarios, 2) están correlacionadas con un sistema de cuatro categoría de puntuación visual del músculo del pecho, y 3) están correlacionadas con el índice de masa escalado (un índice de condición corporal). Las puntuaciones musculares de nuestro dispositivo superaron a las del sistema tradicional de puntuación muscular de cuatro categorías para predecir el índice de masa escalado. Finalmente, nuestros puntajes musculares de los pavitos migratorios (*Setophaga ruticilla*) aumentaron de marzo a mayo mientras se preparaban para la migración de primavera. Dada la precisión del hardware de escaneo 3D utilizado para generar nuestra imagen 3D para imprimir, producimos un medidor de músculo de plástico que es tan preciso y útil como el aluminio original, pero más rentable y ampliamente disponible.

Key words: Afrotropical, Bahamas, body condition, Cameroon, Jamaica, 3D printing, pectoral muscle

¹¹Corresponding author. Email: Luke.L.Powell@gmail.com

The pectoral muscle is the largest organ in a bird's body and, as such, plays a crucial role in avian ecology and life history. It is critical for flight, can be a source of protein (Hartman 1961, Jenni and Jenni-Eiermann 1998, Lindstrom et al. 2000), and serves as a source of water during migratory flights (Gerson and Guglielmo 2011). Pectoral muscle mass changes throughout the year during migration, reproduction, and molt (Veasey and Metcalfe 2001, Dietz et al. 2007). These changes have been considered, in part, to reflect changes in general body condition (Brown 1996, Brown and Sherry 2006, 2008), resulting in downstream impacts on fitness (Marra et al. 1998). For example, Cooper et al. (2015) showed that, after experimental food reduction, wintering American Redstarts (*Setophaga ruticilla*) lost pectoral muscle mass, ultimately resulting in a delayed onset of spring migration, which is a critical predictor of reproductive success (Tonra et al. 2011).

Several approaches and methods are available for estimating avian muscle mass (see Speakman 2001 for a broad overview of body composition analyses). These include destructive approaches that measure the wet mass of dissected tissues (Bauchinger et al. 2011, Swanson and Merkord 2013), measuring muscle thickness through ultrasound (Sears 1988, Dietz et al. 1999), modeling the shape of the flight muscle through wire or dental cast gels (Bolton et al. 1991, Selman and Houston 1996), and nondestructive approaches that indirectly estimate whole-body lean muscle mass (e.g., McWilliams and Whitman 2013). Some of these direct and indirect approaches can be relatively time-consuming (e.g., Selman and Houston 1996), require sophisticated laboratory analyses (McWilliams and Whitman 2013), or require relatively expensive equipment (Dietz et al. 1999); most are either not suitable for small birds or not feasible to use with large numbers of birds such as at banding stations (Bolton et al. 1991, Selman and Houston 1996, Dietz et al. 1999, McWilliams and Whitman 2013). A widely adopted alternative to these techniques relies on a somewhat subjective visual scoring system that categorizes a bird's pectoral muscle mass based on its shape (Jenni and Jenni-Eiermann 1998). Although quick and reasonably repeatable, this four-

category method is not, in our experience, sensitive to small changes in muscle mass that commonly occur, for example, in songbirds as they prepare for migration.

Bauchinger et al. (2011) introduced the "muscle meter," a small aluminum tool that measures the shape of the pectoral muscle in passerines and results in a highly repeatable muscle meter score (hereafter, mm_{score}). A validation study demonstrated that the pectoral muscle mass of a songbird could be estimated with a relative error of only 3%, given mm_{score} , tarsus length, and body mass of the bird, the latter representing measurements typically collected during bird-banding activities. Given the utility of the muscle meter to accurately and non-invasively quantify changes in the pectoral muscle mass of songbirds, we used 3D-scanning and printing technology to produce an inexpensive plastic version of the original aluminum muscle meter and compared its utility to several other indices of pectoral muscle size in seven species of songbirds. The objectives of our field test were to: (1) assess the repeatability of the 3D-printed version of the muscle meter, (2) compare mm_{score} to m_{shape} , a common muscle scoring system where four size categories are visually assessed (Jenni and Jenni-Eiermann 1998), (3) compare predicted pectoral muscle mass to scaled mass index, a commonly used measure of body condition (Peig and Green 2009), and (4) quantify how mm_{score} increase as American Redstarts prepare for spring migration.

METHODS

Muscle meter. We scanned the original muscle meter from Bauchinger et al. (2011) by taking a series of 2D images that we then processed into a 3D model using photogrammetry software (Agisoft Photoscan). The original muscle meter, consisting of two aluminum plates that were bolted together, was disassembled to capture the unique profiles machined into each plate. The reversible nature of each plate allowed us to image these parts from only one side and later digitally mirror the uncaptured surfaces. Because reflective surfaces such as the aluminum construction of the original muscle meter often yield excessive noise in the resulting 3D model, the noisy photogrammetric 3D model

was imported into CAD software (Rhino 3D) and used as a template to create a clean 3D model suitable for 3D printing.

To create a more versatile version of the plastic muscle meter, we combined Bauchinger et al.'s (2011) 6-mm gap version (hereafter, small) and the 10-mm gap version (hereafter, large) of the muscle meter into a single muscle meter so each long end of the meter can be used for different-sized birds (Fig. 1). We then printed the device in "strong and flexible" nylon (now known on Shapeways' website as "versatile plastic") via widely available commercial 3D-printing services (<https://www.shapeways.com>). For instructions on 3D printing these muscle meters, see Appendix S1 and, to access the .stl files, see Appendices S2, S3, and S4.

Study design. To assess the efficacy and repeatability of a 3D-printed version of the breast muscle meter (Bauchinger et al. 2011), we collected muscle size measurements from seven species of songbirds and, when possible, during both breeding and non-breeding seasons. We sought to assess inter-user repeatability and compare mm_{score} to m_{shape} and to provide a field example by comparing breast muscle size to scaled mass index (Peig and Green 2009). Species selected for this analysis were a subset of those captured at each of the respective study sites that had appreciable sample sizes ($N > 30$).

In Cameroon, resident birds were captured in 15 cocoa farms during January and February 2018 and August and September 2019. In Equatorial Guinea, we captured three species of resident birds in primary and secondary forest near Oyala (1.614°, 10.878°) in January and February 2018, including Yellow-whiskered Greenbuls (*Eurillas latirostris*, ~ 27 g), Olive Sunbirds (*Cyanomitra olivacea*, ~ 10 g), and Little Greenbuls (*Eurillas virens*, ~ 23 g). In Jamaica, we captured birds during the non-breeding season (10 January – 10 May) in 2018 and 2019 at the Font Hill Nature Preserve (18.043°, -77.942°) located ~ 12 km west of Black River, St. Elizabeth Parish, Jamaica, West Indies. Species captured included American Redstarts (*Setophaga ruticilla*, ~ 8 g), Black-and-white Warblers (*Mniotilta varia*, ~ 11 g), and Ovenbirds (*Seiurus aurocapilla*, ~ 21 g), all of which are Neotropical-Nearctic migratory songbirds. Kirtland's Warblers (*Setophaga kirtlandii*,

~ 14 g), also Neotropical-Nearctic migrants, were captured from 2017 to 2019 in both their breeding areas in Michigan (44.479°, -84.302°) and non-breeding areas in The Bahamas (24.638°, -75.647°).

We captured birds using mist-nets either passively or using conspecific playback. After capture, we collected standard morphometrics that included body mass (± 0.1 g), unflattened wing chord (± 0.5 mm), m_{shape} (0–3, Jenni and Jenni-Eiermann 1998), and mm_{score} (± 0.01 mm) using the muscle meter. We excluded birds with brood patches. For m_{shape} , we scored birds with strongly concave breast muscles as 0, whereas birds with strongly convex muscles received a score of 3 (see Fig. 2 illustrations). Values of mm_{score} were inverted so that large values of mm_{score} corresponded with larger pectoral muscles.

As in Bauchinger et al. (2011), we blew on breast feathers to reveal the breast area and then measured mm_{score} by placing the center of the gap of the muscle meter down on the center of and perpendicular to the birds' keel. We pressed down on the side of the device with the appropriately sized gap (Fig. 1) until the sides of the gap touched the breast muscle (see Video S1). As with the original aluminum device, the amount of pressure to apply takes some practice and standardization among users; we used the minimum amount of downward pressure such that the device was just touching, but not depressing, the birds' breasts. In some cases, keeping the breast feathers out of the way may require a steady, continuous breath on the breast or, at most, a slight moistening of the feathers with water to move them out of the way. In a minor departure from Bauchinger et al.'s (2011) technique for measuring mm_{score} , we used standard field calipers rather than a custom digital measuring device to measure the separation of the muscle meter parts (see Video S1). We used the small muscle meter gap for birds that weighed < 20 g (Olive Sunbirds and the migratory warblers), and the large gap for birds with mass > 25 g (Little Greenbuls and Yellow-whiskered Greenbuls).

We used a scaled mass index as a measure of body "condition" and calculated it for each individual following Peig and Green (2009). We calculated species-specific scaling coefficients after assessing the relationship between

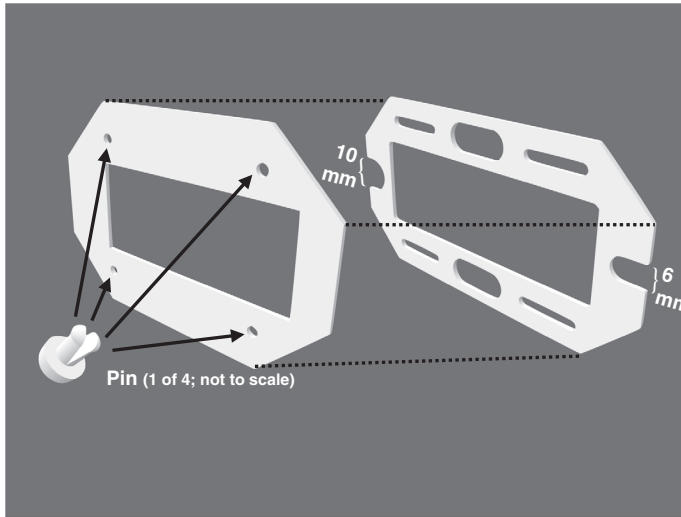

Fig. 1. Schematic of the 3D-printed muscle meter. This version is double-sided with both a 6-mm gap (for small songbirds) and a 10-mm gap (for medium-sized songbirds).

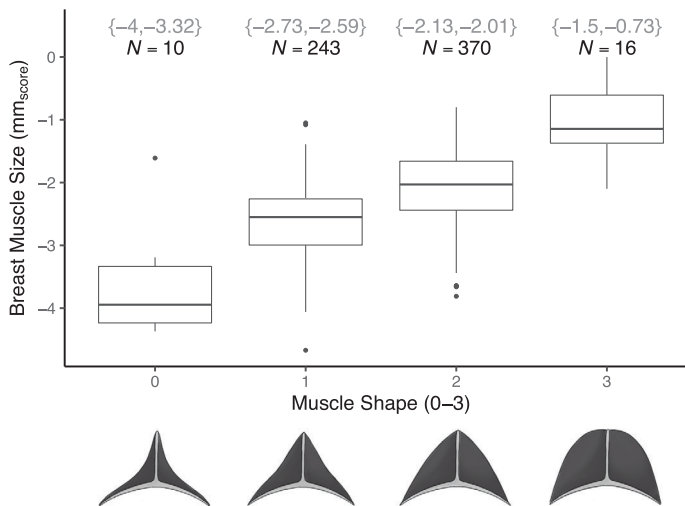

Fig. 2. Relationship between commonly used muscle shape categories (m_{shape}) and muscle meter score (mm_{score}). Grayed values indicate 95% confidence interval of the mm_{score} for each associated muscle shape. Below the x-axis under each representative score is a pictorial representation of the relative size of the pectoral muscle. Box-and-whisker plots show the median (horizontal line in box) and the 25% (lower edge of box) and 75% (upper edge of box) quantiles.

wing length and mass and excluding probable outliers. For this example, we considered heavier individuals (larger scaled mass) to be in better condition, likely due to increased muscle mass. Importantly, body condition is strongly context-dependent and relative scaled mass indices likely represent complex

interactions between individual physiology and their environment across different stages of the annual cycle, so care must be taken when comparing mm_{scores} and scaled mass index.

Statistical analyses. To assess inter-user repeatability, a subset ($N = 127$) of the total

sample ($N = 802$) was subjected to a second muscle size measurement by a separate user. We used the intra-class correlation coefficient (ICC) as an estimate of repeatability and its associated confidence interval following Wolak et al. (2012). For a moderate to highly repeatable measure ($ICC > 0.4$) with only two measures per individual, a sample size of > 122 will provide a confidence interval width of < 0.3 , suggesting that our sample size would allow accurate estimation of the inter-user repeatability for this morphological measure (Wolak et al. 2012).

We used linear models to assess how much variation in mm_{score} was explained by m_{shape} as an indication of how well they correlated qualitatively, i.e., were higher categories of m_{shape} associated with higher means in mm_{score} (Fig. 2). For this analysis, we used a subset ($N = 573$) of the total ($N = 802$) because m_{shape} was not recorded in Cameroon or Michigan. We supported this quantitatively by assessing the correlation between the m_{shape} and mm_{score} (ordinal variable) with a Spearman rank correlation.

As a further test of efficacy of mm_{score} to assess individual condition, we then created three models, including a null model that included species and sex, a mm_{score} model (including species and sex), and an m_{shape} model (including species and sex), and ranked these models using AIC (Burnham and Anderson 2002). These AIC weights allowed us to assess the relative contribution of mm_{score} or m_{shape} to predict variability in scaled mass index (a proxy for condition) after controlling for species and sex differences. As with the previous models, we used a subset ($N = 573$) of the total sample size ($N = 802$) because m_{shape} was not recorded in Cameroon or Michigan and because we wanted samples sizes to be equal between the three models described above. We considered models with $\Delta AIC < 2$ to have an equivalent level of support.

To further examine whether the relationship between scaled mass index varied between seasons, we modeled scaled mass index as a function of mm_{score} , sex, and period specifically for Kirtland's Warblers, which were sampled both in their breeding and non-breeding areas ($N_{breeding} = 57$, $N_{non-breeding} = 132$). Lastly, to determine if the muscle meter could detect differences in mm_{score} leading up to

migration, we used data collected during the winter and pre-migratory periods of American Redstarts in Jamaica ($N = 238$). We assessed the monthly mean mm_{score} for each sex during the mid-winter period (January – March) and during the pre-migratory period (April and May) when this population undergoes rapid changes in body composition (May; Cooper et al. 2015).

Finally, we performed a power analysis using the European Starling dataset ($N = 115$; mean flight muscle mass = 14.97 ± 5.16 [SD] g) from Bauchinger et al. (2011) to determine the difference in breast muscle mass necessary to detect a difference in mm_{score} . We used a linear regression model to compare the group in Bauchinger et al. (2011) to simulated groups of 115 starlings where mean flight muscle mass varied from 0.01 to 4.0 g higher than in Bauchinger et al.'s (2011) group.

All statistical analyses were conducted in Program R (R Core Team 2019) with packages tidyR (Wickham and Henry 2019), ICC (Wolak et al. 2012), and AICcmodavg (Mazerolle 2019). Significance of parameter estimates and statistical tests was evaluated at $P < 0.05$. Values are presented as means ± 1 SD.

RESULTS

The intra-class correlation coefficient for mm_{score} demonstrated that this measurement was moderately repeatable ($ICC = 0.55$ {0.42, 0.66}) and average differences in mm_{score} between users for the same individual were normally distributed ($m = -0.01 \pm 0.62$, Fig. 3). The repeatability estimated in our study was comparable to, albeit lower than, that found by Bauchinger et al. (2011; i.e., 0.79) where three, rather than two, measurements per individual were recorded.

Muscle meter score (mm_{score}) explained a significant portion of the variation in m_{shape} ($R^2 = 0.31$, $F_{3,569} = 84.4$, $P < 0.001$), with increasing m_{shape} categories corresponding to increasing mm_{scores} (Fig. 2). These results were supported quantitatively by a strong positive correlation between mm_{score} and m_{shape} (Spearman rank $\rho = 0.52$, $P < 0.001$). Mean mm_{scores} for each category of m_{shape} were all significantly different from each other because the 95% confidence interval of mm_{score} did

not overlap between m_{shape} categories (Fig. 2).

Of the three models tested, the model that included mm_{score} was a better predictor of scaled mass index than the model that only included m_{shape} ($\Delta\text{AIC} = 12$), and those two models were superior to the null model ($\Delta\text{AIC} = 18.69$ and 669 , respectively). In the best supported model, mm_{score} was significantly correlated with scaled mass index after accounting for differences between species and sex (Fig. 4, adjusted $R^2 = 0.93$, $F_{6,566} = 1270$, $P < 0.001$). The strength of this correlation varied with species, with Black-and-white Warblers and Ovenbirds showing the clearest pattern (Fig. 4, bottom right) and other species, particularly Kirtland's Warblers, showing considerable noise. In general, individuals with larger mm_{score} tended to be heavier after accounting for body size ($b_{\text{mm_score}} = 0.39$, $t_{566} = 4.6$, $P < 0.001$). For Kirtland's Warblers, we found that the mean mm_{score} was significantly larger during the breeding season (-1.93 ± 0.07) than during the non-breeding season (-2.16 ± 0.05 , $b = -0.22$, $F_{1,187} = 7.0$, $P = 0.009$). Despite differences in mm_{scores} between seasons, the interaction between mm_{score} and season (breeding vs. non-breeding) was not significant ($b_{\text{mm_score} \times \text{season}} = 0.48$, $t_{184} = 1.3$, $P = 0.19$).

Wintering American Redstarts had significantly larger mm_{scores} during the pre-migratory period (1 April – 15 May; -2.03 ± 0.06) than during the winter period

(-2.39 ± 0.07 ; $F_{1,236} = 23.1$, $P < 0.001$). Further, mean monthly mm_{scores} increased in the months leading up to the start of migration after accounting for sex ($F_{5,228} = 7.1$, $P < 0.001$). Monthly mean mm_{scores} did not differ between January (-2.50 ± 0.09) and February (-2.51 ± 0.08), but increased significantly during March (-2.27 ± 0.07), April (-2.09 ± 0.06), and May (-1.63 ± 0.22 ; Fig. 5).

Finally, the difference in mm_{scores} between European Starlings in Bauchinger et al.'s (2011) study and our simulated starling groups became statistically significant when mean flight muscle mass increased to 2.3 g between groups. A difference in mean flight muscle of 2.3 g would correspond to an increase in mm_{score} of ~ 2.5 .

DISCUSSION

Given the precision of the 3D-scanning hardware we used to produce our 3D image for printing, we produced a plastic muscle meter that is as precise and useful as the aluminum original, but more cost-effective ($\sim \$30$ USD, $\$15$ of which is for shipping) and easily obtainable. mm_{scores} were repeatable among users and were strongly correlated with the widely used visual scoring method (m_{shape}). mm_{score} outperformed m_{shape} in predicting the scaled mass index of seven species of songbirds. The simple profiles of the original muscle meter may also have been CAD-modeled based on traditional measurement



Fig. 3. Differences in muscle meter score (mm_{score}) between users. Differences between users were normally distributed, and repeatability was moderate. Differences in mm_{score} between users with density plot (black line) overlaid onto histogram. Ticks below histogram represent frequency of observations.

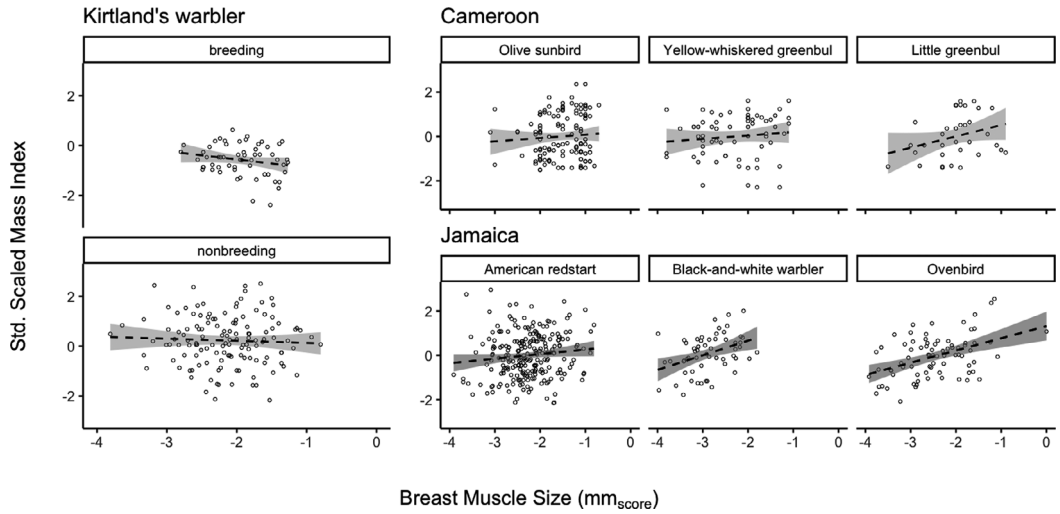

Fig. 4. Relationship between muscle meter score (mm_{score}) and scaled mass index by species across projects and, for Kirtland's Warblers (left), between breeding (Michigan) and non-breeding (Bahamas) seasons. Overall, individuals with larger mm_{score} were significantly heavier after accounting for body size (i.e., scaled mass index). Error shading represents 95% confidence intervals.

tools (e.g., calipers). Physical replication could also be achieved by a variety of materials and fabrication methods (e.g., CNC machining or laser cutting). However, 3D-printing services are widely available and offered a good combination of durability, repeatability, and affordability when ordering parts in low volumes.

Overall, we found that our version of the muscle meter provided repeatable estimates of pectoral muscle size. Repeatability in our study was lower than that reported by Bauchinger et al. (2011), but direct comparison of repeatability between studies is questionable because important determinants of repeatability differed. Bauchinger et al. (2011)

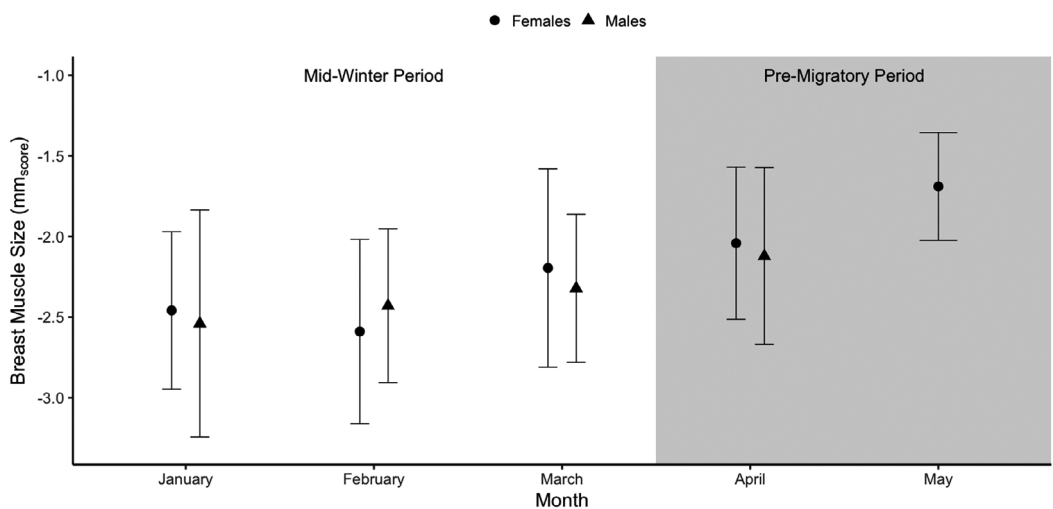

Fig. 5. Mean monthly breast muscle scores (mm_{score}) of wintering American Redstarts leading up to spring migration. mm_{scores} were significantly larger during the pre-migratory period than they were during the winter and increased from March up through departure. Error bars represent standard deviations.

measured two species and took either three measurements or a single measurement per bird, respectively. More importantly, only a single person took all measurements in the Bauchinger et al. (2011) study, whereas different users were involved in our study. Therefore, we provide repeatability estimates that more closely align with typical field use. Wolack et al. (2012) demonstrated that increasing the number of samples taken per individual (k) reduced the uncertainty around the intra-class correlation coefficient, especially when k increased from two to three. We recommend using an average of at least three measurements per individual to further reduce measurement error and, when possible, attempt to standardize measurements among users.

As expected, we found a positive correlation between mm_{scores} and scaled mass index. The relationship between these two variables was strongly and clearly positive for two species (Black-and-white Warblers and Ovenbirds), but noisy for Kirtland's Warblers for reasons that were unclear. Mm_{score} was a substantially better predictor of scaled mass index than m_{shape} , likely due to the finer resolution of the muscle meter measurement, continuous measurement rather than a categorical score. We also found that the muscle meter was sensitive enough to detect monthly differences in muscle size leading up to the start of spring migration for American Redstarts. Average mm_{scores} were larger during the pre-migratory period than during the mid-winter period and, interestingly, mm_{scores} began to increase during March, sooner than what is typically considered the "pre-migratory" period. The relationship between mm_{score} and scaled mass index could indicate a link between pectoral muscle size and body condition in birds, although we acknowledge that many other factors contribute to body condition, including differences among species. We predict that incorporating our high-resolution measurement of pectoral muscle size into calculations of body condition may improve their resolution and precision.

Some versions of our 3D-printed muscle meter had pins that did not fit well and created friction when sliding the two main parts back and forth for the measurement (Fig. 1). We recommend that, if users encounter this issue, they purchase small metal screws,

ideally with one paired with a locking "knurled thumb nut" (e.g., screw type DIN 466; size M2-M3 as in Bauchinger et al. 2011) or a wing nut to secure the two main parts together while the caliper measurement is taken. In addition, we recommend that users not measure birds with brood patches because vascularization of the breast can make the measurement difficult to repeat. Care must also be taken to use the correct gap size; large birds (e.g., > 100 g) may not be particularly suited for even our largest gap size, but this can be assessed on a species-by-species basis.

Finally, unlike Bauchinger et al. (2011), we did not conduct a validation study by relating mm_{scores} to wet pectoral muscle mass measured in collected specimens. Because the relationship between mm_{scores} and wet pectoral muscle mass will differ among species (Bauchinger et al. 2011), using a predictive model to transform mm_{scores} into a direct estimate of muscle mass is preferable. Because collecting specimens for direct measures of wet muscle mass to construct a predictive model is not always feasible, especially for sensitive species like Kirtland's Warblers, we argue that using mm_{scores} serves as a reasonable proxy for pectoral muscle mass. However, care should be taken when interpreting results because mm_{score} is an index of muscle mass and may not be directly comparable among species. Ultimately, with widespread adoption of this 3D-printed muscle meter, we encourage additional studies to calibrate mm_{scores} to wet weights of dissected pectoral muscles of different species of birds that can be done opportunistically (e.g., window strike kills and museum specimens). These calibrations will allow investigators in the future to produce direct estimates of pectoral muscle mass as opposed to using the mm_{score} .

Given the results of our power analysis, we also encourage researchers to consider the sample size required to detect a difference in mm_{scores} in their study system. Our power analysis using 115 European Starlings in two simulated treatment groups required a difference in flight muscle mass of at least 2.3 g (mm_{score} difference ~ 2.5) to detect a difference. Mean flight muscle mass of the European Starlings sampled by Bauchinger et al (2011) had a range of 7.44 g (10.86–18.30 g), so a mean difference between

groups of 2.3 g is considerable, but certainly feasible, and will depend on the study species.

We have included 3D-print schematics that can be used to print devices at a relatively low cost. We improved upon the original design and made it more functional for banding stations by making a double-sided device that can be used on both small- and medium-sized songbirds. Ultimately, this 3D-printed rendition of the muscle meter has shown promise as a rapid, noninvasive, cost-effective, and repeatable method for estimating avian pectoral muscle mass. This device provides a higher-precision method for estimating muscle shape and we recommend that it replace the widely used visual muscle scoring system.

ACKNOWLEDGMENTS

Animals were captured and handled in accordance with Smithsonian Institution IACUC (#14-03) and Durham University's Animal Welfare Ethical Review Board (careBIOL-2019-07-10T12:06:13-rgrnr69). Special thanks to all of the field technicians that helped collect the data for these projects, including Alicia Brunner, Tabe Tiku Regine Claire, Justin Saunders, John and Lizzie Diener, Kirsti Owen, and Silvestre (Nelson) Malanza. Special thanks to D. J. McNeil for providing the flight muscle illustrations in Figure 2. We thank two anonymous reviewers and the editor of JFO for their insightful comments. Fieldwork was funded by a Durham University Junior Research Fellowship (Cameron), Stonehill Education (Equatorial Guinea), James Bond Fund, National Geographic, USFWS Migratory Birds a Smithsonian Fellowship (Michigan and Bahamas), and NSF LTER-B (Jamaica).

LITERATURE CITED

- BAUCHINGER, U., S. R. MCWILLIAMS, H. KOLB, V. M. POPENKO, E. R. PRICE, AND H. BIEBACH. 2011. Flight muscle shape reliably predicts flight muscle mass of migratory songbirds: a new tool for field ornithologists. *Journal of Ornithology* 152: 507–514.
- BOLTON, M., P. MONAGHAN, AND D. C. HOUSTON. 1991. An improved technique for estimating pectoral muscle protein from body measurements of live gulls. *Ibis* 133: 264–270.
- BROWN, D. R., AND T. W. SHERRY. 2006. Food supply controls the body condition of a migrant bird wintering in the tropics. *Oecologia* 149: 22–32.
- BROWN, D. R., AND T. W. SHERRY. 2008. Alternative strategies of space use and response to resource change in a wintering migrant songbird. *Behavioral Ecology* 19: 1314–1325.
- BROWN, M. E. 1996. Assessing body condition in birds. *Current Ornithology* 13: 67–135.
- BURNHAM, K. P., AND D. R. ANDERSON. 2002. Model selection and multimodel inference: a practical information-theoretic approach, 2nd ed. Springer, New York, NY.
- COOPER, N. W., T. W. SHERRY, AND P. P. MARRA. 2015. Experimental reduction of winter food decreases body condition and delays migration in a long-distance migratory bird. *Ecology* 96: 1933–1942.
- DIETZ, M. W., A. DEKINGA, T. PIERSMA, AND S. VERHULST. 1999. Estimating organ size in small migrating shorebirds with ultrasonography: an intercalibration exercise. *Physiological and Biochemical Zoology* 72: 28–37.
- DIETZ, M. W., T. PIERSMA, A. HEDENSTRÖM, AND M. BRUGGE. 2007. Intraspecific variation in avian pectoral muscle mass: constraints on maintaining manoeuvrability with increasing body mass. *Functional Ecology* 21: 317–326.
- GERSON, A. R., AND C. G. GUGLIELMO. 2011. Flight at low ambient humidity increases protein catabolism in migratory birds. *Science* 333: 1434–1436.
- HARTMAN, F. A. 1961. Locomotor mechanisms of birds. *Smithsonian Miscellaneous Collections* 143, Smithsonian Institution, Washington, D.C.
- JENNI, L., AND S. JENNI-EIERMANN. 1998. Fuel supply and metabolic constraints in migrating birds. *Journal of Avian Biology* 29: 521–528.
- LINDSTROM, A., A. KVIST, T. PIERSMA, A. DEKINGA, AND M. W. DIETZ. 2000. Avian pectoral muscle size rapidly tracks body mass changes during flight, fasting and fuelling. *Journal of Experimental Biology* 203: 913–919.
- MARRA, P. P., K. A. HOBSON, AND R. T. HOLMES. 1998. Linking winter and summer events in a migratory bird by using stable-carbon isotopes. *Science* 282: 1884–1886.
- MAZEROLLE, M. J. [online]. 2019. AICcmodavg: model selection and multimodel inference based on (Q)AIC(c). <<http://CRAN.R-project.org/package=AICcmodavg>>.
- MCWILLIAMS, S. R., AND M. WHITMAN. 2013. Non-destructive techniques to assess body composition of birds: a review and validation study. *Journal of Ornithology* 154: 597–618.
- PEIG, J., AND A. J. GREEN. 2009. New perspectives for estimating body condition from mass/length data: the scaled mass index as an alternative method. *Oikos* 118: 1883–1891.
- R CORE TEAM. 2019. R: a language and environment for statistical computing. R Foundation for Statistical Computing, Vienna, Austria.
- SEARS, J. 1988. Assessment of body condition in live birds; measurements of protein and fat reserves in the Mute Swan, *Cygnus olor*. *Journal of Zoology* 216: 295–308.
- SELMAN, R. G., AND D. C. HOUSTON. 1996. A technique for measuring lean pectoral mass in small live birds. *Ibis* 138: 348–350.
- SPEAKMAN, J. R. 2001. Body composition analysis of animals: a handbook of non-destructive methods. Cambridge University Press, Cambridge, UK.
- SWANSON, D. L., AND C. MERKORD. 2013. Seasonal phenotypic flexibility of flight muscle size in small

birds: a comparison of ultrasonography and tissue mass measurements. *Journal of Ornithology* 154: 119–127.

- TONRA, C. M., P. P. MARRA, AND R. L. HOLBERTON. 2011. Migration phenology and winter habitat quality are related to circulating androgen in a long-distance migratory bird. *Journal of Avian Biology* 42: 397–404.
- VEASEY, J., AND N. B. METCALFE. 2001. A hidden cost of reproduction: the trade-off between clutch size and escape take-off speed in female Zebra Finches. *Journal of Animal Ecology* 70: 20–24.
- WICKHAM, H., AND L. HENRY [online]. 2019. tidy: easily tidy data with “spread” and “gather” functions. <<https://cran.r-project.org/package=tidy>>.
- WOLAK, M. E., D. J. FAIRBAIRN, AND Y. R. PAULSEN. 2012. Guidelines for estimating repeatability. *Methods in Ecology and Evolution* 3: 129–137.

SUPPORTING INFORMATION

Additional Supporting Information may be found in the online version of this article at the publisher’s website.

Appendix S1. 3D printing instructions.

Appendix S2. Muscle Meter Part A.

Appendix S3. Muscle Meter Part B.

Appendix S4. Muscle Meter pin.

Video S1. Demonstration of the use of the muscle meter.